



**CONSTRUCTION DETAIL**

**CONSTRUCTION DETAIL (CONTINUED)**

Element	Cd	Description	Element	Cd	Description
Style: 105		Custom Design	Fireplaces	1	
Model: 01		Residential	Ceiling Height	8.00	
Grade: 17		Type 1+	Elevator		
Stories: 2		2 Stories	<b>CONDO DATA</b>		
Occupancy: 1		Wood Shingle	Parcel Id		
Exterior Wall 1: 14		Gable	Adjust Type		
Exterior Wall 2: 03		Asphalt Shingl	Condo Flr		
Roof Structure: 03		Drywall	Condo Unit		
Roof Cover: 05		Hardwood	<b>COST/MARKET VALUATION</b>		
Interior Wall 1: 12		Gas	Building Value New	2,034,201	
Interior Wall 2: 03		Forced Air	Year Built	1967	
Interior Fir 1: 04		Central	Effective Year Built	V/G	
Interior Fir 2: 03		2 Bedrooms	Depreciation Code		
Heat Fuel: 02		1 Full Bath	Remodel Rating	G	
Heat Type: 03			Year Remodeled	2023	
AC Type: 03		8 Rooms	Depreciation %	3	
Total Bedrooms: 02		Modern	Functional Obsol	0	
Total Baths: 1		Modern	External Obsol	0	
Total Xtra Fixtrs: 0			Trend Factor	1	
Total Rooms: 8			Condition	UC	
Bath Style: 03			Condition %	40	
Kitchen Style: 03			Percent Good	40	
Kitchens: 1			Cns Sect Rchld	400,300	
Whirlpool Tubs: 1			Dep % Ovr		
Hot Tubs: 1			Dep Ovr Comment		
Sauna (SF Area): 406		Living Area Q	Misc Imp Ovr		
Fin Basement: 4			Misc Imp Ovr Comment		
Fin Bmnt Qual: 3			Cost to Cure Ovr		
Bsmnt Garages: 3			Cost to Cure Ovr Comment		
Interior Cond: 5					
Fireplaces: 1					
Ceiling Height: 8.00					

**OB - OUTBUILDING & YARD ITEMS (L) X F - BUILDING EXTRA FEATURES (B)**

Code	Description	LB	Units	Unit Price	Yr Bfr	Cond	Cd	% Gd	Grade	Grade Adj.	Appr. Value
SPL1	InGround Pool	L	800	50.50	2023	6		75	5	1.75	53,000
PAT1	Patio	L	1,184	16.50		6		75	5	1.75	25,600

**BUILDING SUB-AREA SUMMARY SECTION**

Code	Description	Living Area	Floor Area	Eft Area	Unit Cost	Undeprec Value
BAS	First Floor	3,305	3,305		230.94	763,257
BSM	Basement Area	0	2,745		46.19	126,786
CRL	Crawl Space	0	160		0.00	0
FOP	Porch, Open	0	60		46.19	2,771
PRS	Piers	0	280		0.00	0
PTS	Patio - Stone	0	132		34.99	4,619
SLB	Slab	0	120		0.00	0
VLT	Vaulted Ceiling	0	376		11.67	4,388
WDK	Deck, Wood	0	459		23.14	10,623
<b>Ttl Gross Liv/Lease Area</b>		<b>3,305</b>	<b>7,637</b>			<b>912,444</b>

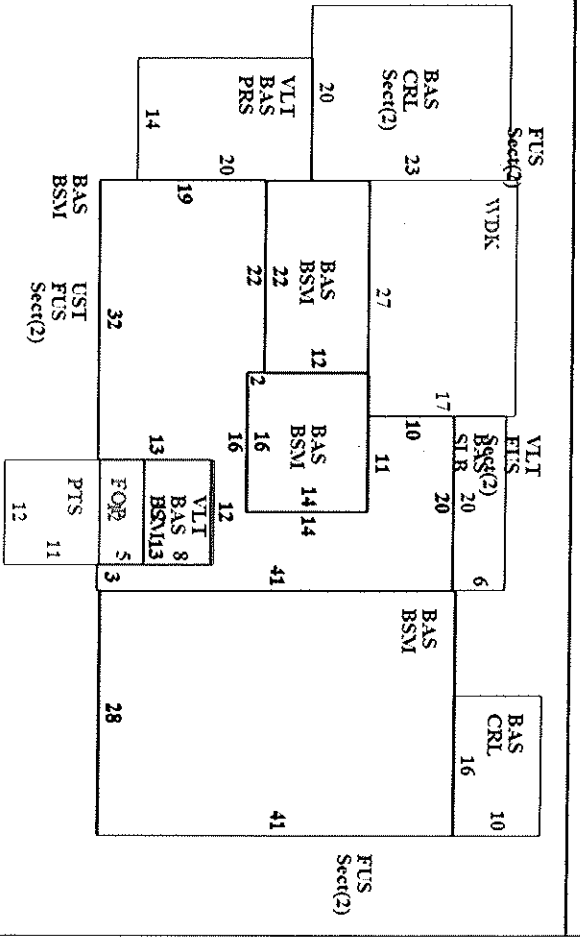



**CONSTRUCTION DETAIL**

**CONSTRUCTION DETAIL (CONTINUED)**

Element	Cd	Description	Element	Cd	Description
Style: 105		Custom Design	Fireplaces		
Model: 01		Residential	Ceiling Height	8.00	
Grade: 17		Type 1+	Elevator	2	
Stories: 2		2 Stories	<b>CONDO DATA</b>		
Occupancy: 1		Wood Shingle	Parcel Id		
Exterior Wall 1: 14		Gable	Adjust Type		
Exterior Wall 2: 03		Asphalt Shingl	Condo Fir		
Floor Structure: 03		Drywall	Condo Unit		
Roof Cover: 05			<b>COST/MARKET VALUATION</b>		
Interior Wall 1: 12		Hardwood	Building Value New	2,034,201	
Interior Wall 2: 15		Quarry Tile	Year Built	2023	
Interior Fir 1: 03		Gas	Effective Year Built		
Interior Fir 2: 04		Forced Air	Depreciation Code		
Heat Fuel: 03		Central	Remodel Rating		
AC Type: 03		4 Bedrooms	Year Remodeled		
Total Bedrooms: 04		4 Full Baths	Depreciation %		
Total Half Baths: 4		1 Half Bath	Functional Obsol		
Total Xtra Fixts: 1		7 Rooms	External Obsol		
Total Rooms: 7		Modern	Trend Factor	1	
Bath Style: 03		Modern	Condition	UC	
Kitchen Style: 03		Modern	Condition %	20	
Kitchens: 1			Percent Good	20	
Whirlpool Tubs: 1			Cns Sect Rchld	206,700	
Hot Tubs: 1			Dep % Ovr		
Sauna (SF Area): 1			Dep Ovr Comment		
Fin Basement: 1			Misc Imp Ovr		
Fin Bsmnt Qual: 3			Misc Imp Ovr Comment		
Bsmnt. Garages: VG			Cost to Cure Ovr		
Interior Cond: 3			Cost to Cure Ovr Comment		
Fireplaces: 8.00			<b>OB - OUTBUILDING &amp; YARD ITEMS(L)/XF - BUILDING EXTRA FEATURES(B)</b>		

**BUILDING SUB-AREA SUMMARY SECTION**

Code	Description	Living Area	Floor Area	Eff Area	Unit Cost	Undeprac Value
BAS	First Floor	460	460		247.94	114,052
CRL	Crawl Space	0	460		0.00	0
FUS	Upper Story, Finished	2,649	2,649		247.94	656,793
UST	Utility, Storage	0	1,013		111.61	113,061
VLt	Vaulted Ceiling	0	224		12.18	2,727
Ttl Gross Liv/Lease Area		3,109	4,806			886,633

