

**GENERAL NOTES**

- LOT LINE & TOPOGRAPHIC INFORMATION FOR 134 CROSS HIGHWAY TAKEN FROM ZONING LOCATION & TOPOGRAPHIC SURVEY PREPARED BY LANDTECH DATED 6/10/2024.
- DATUM: NAVD 88
- THE CONTRACTOR IS SPECIFICALLY CAUTIONED THAT THE LOCATION AND/OR ELEVATION OF EXISTING UNDERGROUND PIPING, UTILITIES, AND OTHER FEATURES ARE TAKEN FROM EXISTING AS-BUILT MAPPING AND OTHER SOURCES OF INFORMATION AND ARE APPROXIMATE. THE INFORMATION IS NOT TO BE RELIED UPON AS BEING EXACT OR COMPLETE. IN ADDITION, THERE MAY BE OTHER UNDERGROUND PIPING, UTILITIES, AND OTHER FEATURES PRESENT THAT ARE NOT SHOWN. THE CONTRACTOR MUST CALL THE APPROPRIATE UTILITY COMPANY AT LEAST 48 HOURS BEFORE EXCAVATION TO REQUEST EXACT FIELD LOCATION OF UTILITIES. THE CONTRACTOR IS RESPONSIBLE FOR DETERMINING THE PRESENCE OF ANY OF THESE EXISTING ELEMENTS BY WHATEVER MEANS NECESSARY AND PROTECTING THESE ELEMENTS AS REQUIRED OR RELOCATING THEM IF THEY ARE IN CONFLICT WITH THE PROPOSED IMPROVEMENTS SHOWN ON THE PLANS.
- IT IS THE RESPONSIBILITY OF THE CONTRACTOR TO CALL "CALL BEFORE YOU DIG" 1-800-922-4455, THREE FULL WORKING DAYS PRIOR TO ANY EXCAVATION WORK ON THE PROPERTY.
- WETLAND LINE REPRODUCED FROM CONSERVATION COMMISSION MAP F-13. REFER TO LOCATION SURVEY OF LEASED PARCEL PREPARED BY WALTER H. SKIDD LAND SURVEYOR, LLC DATED APRIL 15, 2013 REVISED MAY 31, 2013.
- SUBJECT PROPERTY IS LOCATED IN FEMA FLOOD HAZARD ZONES "X" & "AE" AS SHOWN ON FEMA FIRM PANEL No. 09001C 0412F, EFFECTIVE 6/19/2010.
- A NEW BENCHMARK SHALL BE SET PRIOR TO THE COMMENCEMENT OF CONSTRUCTION.
- ALL EROSION AND SEDIMENT CONTROL MEASURES SPECIFIED IN THE PLAN SHALL BE MAINTAINED UNTIL DISTURBED AREAS.

ZONING DATA				
ZONING DISTRICT: RESIDENCE AAA DISTRICT				
134 CROSS HIGHWAY				
DIMENSIONAL	REQUIRED/ALLOWED	EXISTING	PROPOSED	CONFORMS
LOT AREA	87,120 SF (2.0 AC.)	4,457,495 SF (102.33 AC.)	4,457,495 SF (102.33 AC.)	Y
BASE LOT AREA	1,006,557 SF (23.0 AC.)	1,006,557 SF (23.0 AC.)	91,682 SF (2.104 AC.)	Y
TOTAL COVERAGE	MAX 25% / 22,921 SF	26.1% / 1,052,213 SF	26.1% / 1,052,313 SF	N <sup>3</sup>
SHAPE	MINIMUM 200' SQUARE	200' SQUARE	200' SQUARE	Y
YARDS	FRONT	50'	Existing	N <sup>1</sup>
	SIDE	50'	Existing	Y
	REAR	50'	Existing	N <sup>1</sup>
BUILDING HEIGHT	MAXIMUM 3 STORIES	N/A (CORNER LOT)	N/A (CORNER LOT)	-
		EXISTING	EXISTING	-

NOTES:  
 1. EXISTING NON-CONFORMING  
 2. AREA AND COVERAGE INFORMATION COMPILED FROM BEDFORD M.S. & STAPLES H.S. PARTIAL SITE PLAN PREPARED BY PHILLIP H. CERRONE III, AIA, NCARB ARCHITECT DATED 5/5/23 AND LOT LINE AND 134 CROSS HIGHWAY WESTPORT, CT ZONING LOCATION SURVEY PREPARED BY LANDTECH DATED 5/2/2024  
 3. VARIANCE REQUESTED.

PROPERTY INFORMATION			
OWNER: WAKEMAN TOWN FARMS			
SITE: 134 CROSS HIGHWAY			
ZONE: RESIDENCE AAA DISTRICT			
TOTAL SITE AREA: 102,330 AC., 4,457,495 SF			
LOT AREA / COVERAGE CALCULATIONS			
1.	TOTAL LOT AREA (GROSS)		4,457,495 SF
2.	ABOVE GROUND UTILITY EASEMENTS	0	
3.	STREETS, ROADS, & ACCESSWAYS	0	
4.	OTHER EXCLUSIVE SURFACE EASEMENTS	0	
5.	TOTAL EASEMENTS & ROADS (SUM OF LINES 2, 3, AND 4)		0 SF
6.	WETLAND AREAS	178207	
7.	STEEP SLOPES > 25%	360878	
8.	TOTAL WETLANDS & STEEP SLOPES (SUM OF LINES 6 & 7)	539084	
9.	WETLANDS / SLOPES REDUCTION	0.80 x LINE 8	431268 SF
10.	BASE LOT AREA (LINE 1 MINUS LINES 5 AND 9)		4,026,227 SF
ALLOWABLE LOT COVERAGE			
11.	BASE LOT AREA x 25%	LINE 10 x 0.25	1,006,557 SF
EXISTING LOT COVERAGE			
12.	MIDDLE SCHOOL	2604 SF	1,052,213 SF
	HIGH SCHOOL	124582 SF	
	PAVEMENT ASSOCIATED WITH MIDDLE / HIGH SCHOOL	267894 SF	
	TENNIS COURTS & TRACK	645995 SF	
	FRAME BUILDING	2604 SF	
	DRIVEWAY	6082 SF	
	PORTION OF BARN	1234 SF	
	SMALL BARN	205 SF	
	GREENHOUSE	198 SF	
	GOAT HOUSE	238 SF	
	PORCHES	501 SF	
	GRILL AREA & PIZZA OVEN	77 SF	
13.	SUM OF LINE 12		1,052,213 SF
PROPOSED LOT COVERAGE			
14.	EXISTING LOT COVERAGE	1,052,213 SF	1,052,313 SF
15.	BARN ADDITION	100 SF	
14.	ALLOWABLE LOT COVERAGE	SUM OF LINE 14	1,052,313 SF
15.	EXISTING LOT COVERAGE	26.1%	1,052,213 SF
16.	PROPOSED LOT COVERAGE	26.1%	1,052,313 SF

NOTES:  
 COVERAGE INFORMATION COMPILED FROM BEDFORD M.S. & STAPLES H.S. PARTIAL SITE PLAN PREPARED BY PHILLIP H. CERRONE III, AIA, NCARB ARCHITECT DATED 5/5/23 AND LOT LINE AND 134 CROSS HIGHWAY WESTPORT, CT ZONING LOCATION SURVEY PREPARED BY LANDTECH DATED 5/2/2024

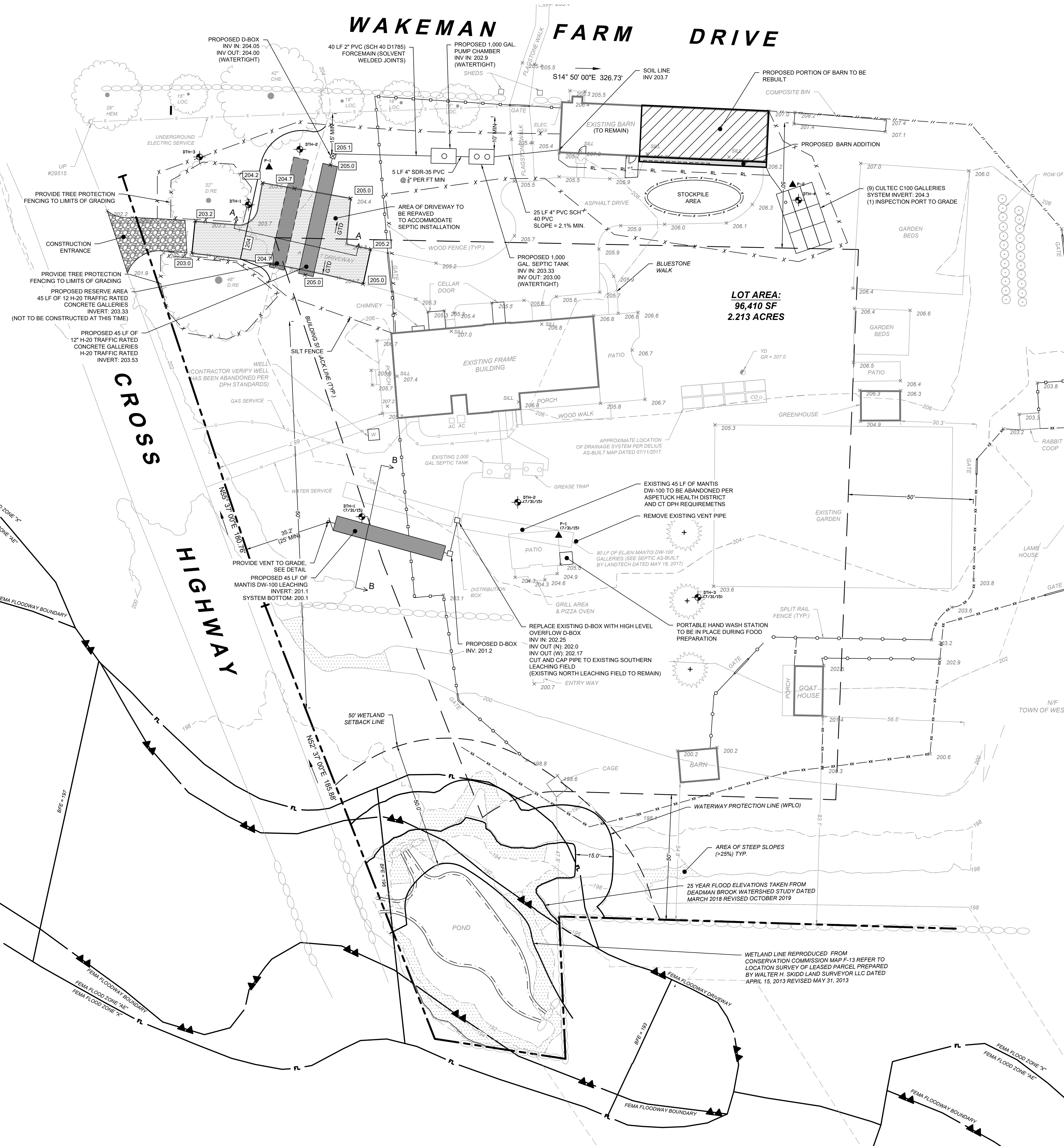

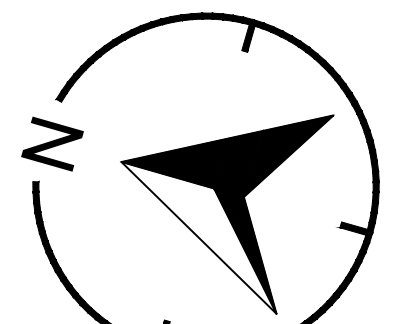

**LOCATION MAP (NTS)**

9/11/2024	REVISED COVERAGE CHART
8/30/2024	REVISED PER AHD COMMENTS
7/8/2024	REVISED TO SHOW WPLO LINE
REVISION DATE	ISSUE

# LANDTECH

SITE/CIVIL • ENVIRONMENTAL • SURVEYING • PLANNING  
 518 RIVERSIDE AVENUE • WESTPORT, CT 06880 • 203-454-2110  
 HELLO@LANDTECHCONSULT.COM • WWW.LANDTECHCONSULT.COM

PREPARED FOR: **WAKEMAN TOWN FARM**

PROJECT LOCATION: **134 CROSS HIGHWAY WESTPORT CT**

PROJECT TITLE: **SITE IMPROVEMENTS FOR A PROPOSED BARN ADDITION**

DRAWING TITLE: **SITE DEVELOPMENT PLAN**

PROJECT No: **24084-01**

DATE: 6/12/2024	DESIGNED BY: RW	CHECKED BY: AS
-----------------	-----------------	----------------

SCALE: 1" = 20'

IN FEET



PROJECT STATUS: **DESIGN DEVELOPMENT NOT FOR CONSTRUCTION**

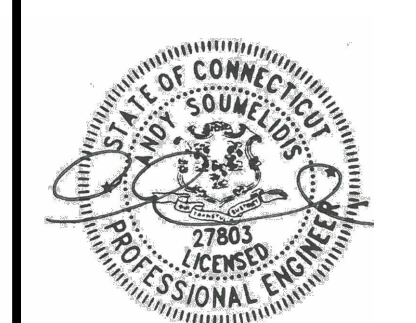

**C-1.0**



GENERAL EROSION AND SEDIMENT CONTROL NOTES

- 1. LAND DISTURBANCE WILL BE KEPT TO A MINIMUM; RE-STABILIZATION WILL BE SCHEDULED AS SOON AS POSSIBLE.
2. SILT FENCE WILL BE INSTALLED ALONG THE TOE OF ALL CRITICAL CUT AND FILL SLOPES, SOIL STOCKPILE AREAS, AND IN THOSE AREAS SHOWN ON THE PLAN.
3. ALL EROSION AND SEDIMENT CONTROL MEASURES WILL BE CONSTRUCTED IN ACCORDANCE WITH THE STANDARDS AND SPECIFICATIONS OF THE STATE OF CONNECTICUT GUIDELINES FOR SOIL EROSION AND SEDIMENT CONTROL, 2002.
4. EROSION AND SEDIMENT CONTROL MEASURES WILL BE INSTALLED PRIOR TO LAND DISTURBANCE WHENEVER POSSIBLE.
5. ALL TEMPORARY EROSION AND SEDIMENTATION CONTROL MEASURES SHALL BE PROPERLY MAINTAINED UNTIL STABILIZATION HAS BEEN ACHIEVED.
6. ADDITIONAL CONTROL MEASURES WILL BE INSTALLED DURING THE CONSTRUCTION PERIOD IF NECESSARY OR REQUIRED, A MINIMUM OF 50 FEET OF SILT FENCE SHALL BE STORED AT THE SITE FOR EMERGENCY USE.
7. ANY EXCAVATIONS THAT MUST BE DEWATERED WILL BE PUMPED INTO A 15x15' DIRTBAG ON-SITE. THE INLETS OF ALL PUMPS ARE TO BE FLOATED A MINIMUM OF 24 INCHES OFF THE BOTTOM OF THE EXCAVATION. THE CONTRACTOR SHALL KEEP A MINIMUM OF (2) 15x15' DIRTBAGS ON-SITE THROUGHOUT THE EXCAVATION OF PROPOSED FOUNDATIONS.
8. WATER AND CALCIUM CHLORIDE SHALL BE APPLIED TO UNPAVED ACCESSWAYS TO PREVENT WIND GENERATED SEDIMENTS AND DUST.
9. DEBRIS AND OTHER WASTES RESULTING FROM EQUIPMENT MAINTENANCE AND CONSTRUCTION ACTIVITIES WILL NOT BE DISCARDED ON-SITE.
10. SEDIMENT REMOVED FROM CONTROL STRUCTURES WILL BE DISPOSED OF IN A MANNER WHICH IS CONSISTENT WITH INTENT OF THE PLAN.
11. SILT FENCES SHALL HAVE SEDIMENT REMOVED WHEN THE DEPTH OF THE SEDIMENT IS EQUAL TO 1/2 TO 2/3 THE HEIGHT OF THE FENCE. FENCES SHALL BE PROPERLY INSTALLED AND RIPPED FENCE OR BROKEN POSTS REPAIRED AS SOON AS PRACTICAL.
12. ANTI-TRACKING PADS AND GRAVEL CHECK DAMS SHALL BE REPLACED WHEN VOID SPACES ARE FULL OR STRUCTURES ARE BREACHED, AS APPLICABLE.
13. TEMPORARY EROSION CONTROL MEASURES SHALL BE REMOVED AND THE SOIL SURFACE STABILIZED WHEN CONSTRUCTION IS COMPLETE AND THE SOIL SURFACES ARE PERMANENTLY STABILIZED. STRUCTURAL COMPONENTS SHALL BE CLEANED OF ALL SEDIMENT UPON COMPLETION OF CONSTRUCTION.
14. THE OWNER IS ASSIGNED THE RESPONSIBILITY FOR IMPLEMENTING THIS EROSION AND SEDIMENT CONTROL PLAN. THIS RESPONSIBILITY INCLUDES INSTALLATION AND MAINTENANCE OF CONTROL MEASURES. INFORMING ALL PARTIES ENGAGED ON THE CONSTRUCTION SITE OF THE REQUIREMENTS AND OBJECTIVES OF THE PLAN, NOTIFYING THE PLANNING AND ZONING COMMISSION OF ANY TRANSFER OF THIS RESPONSIBILITY, AND FOR CONVEYING A COPY OF THE EROSION AND SEDIMENT PLAN IF AND WHEN THE TITLE OF LAND IS TRANSFERRED.

ROOT PRUNING NOTES

- 1. ROOT PRUNING SHALL BE DONE WHENEVER THERE WILL BE GRADING, CUTTING OR COMPACTION DISTURBANCE UNDERNEATH THE DRIP LINE OF A TREE. PRIOR TO ANY WORK WITHIN DRIP LINE, CONTRACTORS SHOULD CONTACT LANDSCAPE SERVICES TO COORDINATE WORK. ROOT PRUNING SHALL BE DONE PRIOR TO DISTURBANCE OF THE SITE. NO DISTURBANCE SHALL BE DONE WITHIN A DISTANCE OF 3X THE DIAMETER OF THE TREE, DUE TO STABILITY CONCERNS.
2. BEFORE DISTURBANCE, MEET WITH PROJECT ARBORIST ON SITE TO CONFIRM LOCATION OF ROOT PRUNING. ROOT PRUNING SHALL BE CONDUCTED AT AN AGREED UPON LOCATION. THIS LOCATION WILL BE MARKED ON THE GROUND BETWEEN THE DISTURBANCE AND THE TREE, TYPICALLY 6' CLOSER TO THE TREE THAN EDGE OF THE DISTURBANCE.
3. ALL ROOTS 3/4" - 1 1/2" DIAMETERS MUST BE PRUNED. IF 2 1/2" OR LARGER ROOTS ARE ENCOUNTERED, STOP PRUNING IN THAT AREA AND CONTACT PROJECT ARBORIST. ROOT PRUNING SHALL ONLY BE AS DEEP AS NECESSARY TO ENSURE THE CUTTING OF ALL ROOTS WHICH WOULD BE IMPACTED BY THE DISTURBANCE.
4. ROOT PRUNING SHALL BE DONE WITH A SHARP TOOL, IN SUCH A WAY THAT DOES NOT PULL ON THE ROOTS, BUT LEAVES SMOOTH CUTS. IT IS PREFERABLE TO EXPOSE THE ROOTS PRIOR TO ROOT PRUNING. AFTER PRUNING, FILL THE AREA WITH QUALITY TOPSOIL AND WATER UNTIL THOROUGHLY SOAKED.
5. ONCE EXPOSED, ROOTS MUST BE COVERED WITHIN 8 HOURS. IF ROOTS WILL BE LEFT EXPOSED FOR LONGER THAN 8 HOURS, THEY MUST BE KEPT MOIST. ONE OPTION IS TO PUT MOIST BURLAP OVER THE EXPOSED ROOTS.
6. ROOT PRUNING SHALL BE DONE BY OR UNDER THE SUPERVISION OF A CERTIFIED ARBORIST, AND MEET OR EXCEED ANSI A300 OR APPROVED TREE CARE INDUSTRY STANDARDS.
7. BEFORE DIGGING
a) FIRST, CONTACT PROJECT ARBORIST AND ARRANGE A SITE VISIT TO DISCUSS LOGISTICS
ii) DURING THE SITE VISIT, CONTRACTOR AND PROJECT ARBORIST WILL DECIDE WHERE THE ROOT PRUNING TRENCH MUST BE DIG
iii) THE LOCATION OF THE ROOT PRUNING TRENCH WILL BE MARKED ON THE GROUND
b) CONTRACTOR WILL PERFORM ROOT PRUNING UNDER THE SUPERVISION OF AN ARBORIST, OR HAVE AN ARBORIST PERFORM THE PRUNING.
ii) A CERTIFIED ARBORIST MUST BE ON-SITE TO PERFORM OR SUPERVISE THE ROOT PRUNING
c) IF MAJOR ROOTS WILL BE PRUNED, OR A LARGE PERCENTAGE OF THE ROOTS WILL BE PRUNED, THE TREE MAY REQUIRE OTHER TYPES OF CARE
i) FOR MATURE TREES, NO MORE THAN 30% OF ROOTS MAY BE PRUNED.
8. DIGGING PROCESS
a) THE PRUNING TRENCH SHOULD BE CLEARED IN A WAY THAT EXPOSES THE ROOTS WHILE LEAVING THEM INTACT.
ii) USE HAND TOOLS OR AN AIR KNIFE
iii) DO NOT USE AN EXCAVATOR, AS THIS WILL PULL ON THE ROOTS AND POSSIBLY DAMAGE THE TRUNK
iii) IF A ROOT LARGER THAN 2" IS EXPOSED, LEAVE THIS ROOT INTACT AND CONTACT LANDSCAPE SERVICES
b) ONCE THE ROOTS ARE EXPOSED, USE A SHARP TOOL TO CLEANLY CUT ALL ROOTS WHICH ARE BETWEEN 1-2" DIAMETER, TO THE DEPTH OF THE PROPOSED DISTURBANCE
i) APPROPRIATE TOOLS INCLUDE SHARP LOPPING SHEARS, HANDSAWS, A SHARPENED AX, A ROOT PRUNER, A STUMP GRINDER, A RECIPROCATING SAW (SAWSALL) AND ANY OTHER SHARP TOOL WHICH LEAVES A CLEAN CUT
iii) YOU MAY NOT USE A CHAINSAW OR CHAIN TRENCHER TO MAKE THE FINAL CUTS
iii) ALL ROOTS SHALL BE LEFT WITH A CLEAN, SMOOTH ENDS AND NO RAGGED EDGES
9. POST PRUNING
a) TREE ROOTS MUST BE KEPT MOIST. IF ROOTS ENDS WILL BE LEFT EXPOSED FOR MORE THAN 8 HOURS, COVER THE HOLE WITH MOIST BURLAP.
b) FILL THE HOLE WITH HIGH QUALITY TOP SOIL, MULCH THE AREA WITH TRIPLE SHREDDED HARDWOOD TO A DEPTH OF 3", AND WATER WELL.

EXCAVATION/FILL NOTES:

- 1. NO PROCESSING OF EARTH OF ANY KIND SHALL BE CONDUCTED ON THE SITE EXCEPT FOR MATERIAL THAT IS EXCAVATED DIRECTLY FROM THE PROJECT SITE FOR USE ON THE PROJECT SITE.
2. THERE SHALL BE NO SHARP DECLIVITIES, PITS OR DEPRESSIONS.
3. PROPER SURFACE DRAINAGE SHALL BE PROVIDED AND GROUNDWATER SHALL NOT BE POLLUTED.
4. AFTER EXCAVATION OR FILLING, THE PREMISES SHALL BE CLEARED OF DEBRIS AND TEMPORARY STRUCTURES WITHIN THE TIME PROVIDED IN THE PERMIT.
5. FILL MATERIAL SHALL NOT INCLUDE ORGANIC (FOR EXAMPLE TREE STUMPS, LEAVES, BRUSH OR OTHER MATERIALS THAT DECOMPOSE, ETC.) OR PETROLEUM BASED PRODUCTS OR MATERIALS.
6. MAXIMUM CUT/FILL:
BASE LOT AREA (SQUARE FEET) X 50% OF THE ALLOWABLE TOTAL COVERAGE PERCENTAGE IN RESPECTIVE ZONE X 10' DIVIDED BY 27 CUBIC FEET =
22,921 SF X (0.5 X 25%) X 10' / 27 = 1,061.2 CY
PROPOSED FILL: 100 CY
PROPOSED CUT: 0 CY

TREE PROTECTION NOTES

- 1. ALL TREES WHICH ARE TO REMAIN ON SITE SHALL BE PROTECTED WITH A (4') TALL BRIGHTLY COLORED PLASTIC FENCE, OR SILT FENCE, PLACED AT THE DRIP LINE OF THE TREES.
2. A ROOT PROTECTION ZONE WILL BE ESTABLISHED AROUND EACH TREE OR ANY VEGETATION TO BE PRESERVED BASED ON DISCUSSIONS WITH THE NEIGHBOR. THE ROOT PROTECTION ZONE SHALL BE AN AREA DEFINED BY THE RADIUS EXTENDING OUTWARD FROM THE TRUNK OF THE TREE. THE ROOT PROTECTION ZONE WILL BE ESTABLISHED AROUND EACH TREE OR ANY VEGETATION TO BE PRESERVED. THE ROOT PROTECTION ZONE SHALL BE AN AREA DEFINED BY THE RADIUS EXTENDING OUTWARD FROM THE TRUNK OF THE TREE A DISTANCE OF ONE (1) LINEAR FOOT FOR EACH DIAMETER INCH AT BREAST HEIGHT OF THE TREE. FOR EXAMPLE, A 10-INCH DIAMETER TREE WILL HAVE A 10-FOOT RADIUS ROOT PROTECTION ZONE.
3. PRIOR TO THE PRE-CONSTRUCTION MEETING, ALL TREE MARKINGS AND PROTECTIVE FENCING SHALL BE INSTALLED BY THE OWNER AND SHALL BE INSPECTED BY THE DEVELOPMENT SERVICES LANDSCAPE ARCHITECT. NO WORK SHALL BEGIN WHERE TREE PROTECTION FENCING HAS NOT BEEN INSTALLED, MAINTAINED AND REPAIRED BY THE CONTRACTOR DURING CONSTRUCTION. THE FENCING WILL BE A MINIMUM OF 4 FEET HIGH.
4. NO EQUIPMENT SHALL BE CLEANED, OR HARMFUL LIQUIDS DEPOSITED WITHIN THE LIMITS OF THE ROOT ZONE OF TREES WHICH REMAIN ON SITE.
5. ROOTS OR BRANCHES IN CONFLICT WITH CONSTRUCTION SHALL BE CUT CLEANLY ACCORDING TO PROPER PRUNING METHODS.
6. NO SIGNS, WIRES, OR OTHER ATTACHMENTS SHALL BE ATTACHED TO ANY TREE TO REMAIN ON SITE.
7. VEHICULAR AND CONSTRUCTION EQUIPMENT SHALL NOT PARK OR DRIVE WITHIN THE LIMITS OF THE DRIP LINE. GRADE CHANGES IN EXCESS OF 3 INCHES (CUT OR FILL) SHALL NOT BE ALLOWED WITHIN A ROOT ZONE, UNLESS ADEQUATE TREE PRESERVATION METHODS ARE IN PLACE.
8. TRENCHING SHALL BE MINIMIZED WITHIN THE DRIP-LINE OF A TREE. ALL REMOVED TREES SHALL BE CHIPPED AND USED FOR MULCH ON SITE OR HAULLED OFF-SITE.
9. EXPOSED ROOTS SHALL BE COVERED AT THE END OF THE WORK DAY USING TECHNIQUES SUCH AS COVERING WITH SOIL, MULCH, OR WET BURLAP.
10. TREE WHICH ARE DAMAGED OR LOST DUE TO THE CONTRACTOR'S NEGLIGENCE DURING THE CONSTRUCTION PHASE SHALL BE MITIGATED.
11. TREES MUST BE MAINTAINED IN GOOD HEALTH THROUGHOUT THE CONSTRUCTION PROCESS. MAINTENANCE MAY INCLUDE WATERING THE ROOT PROTECTION ZONE OR WASHING FOLIAGE.
12. ALL TREE MAINTENANCE TECHNIQUES SHALL BE IN CONFORMANCE WITH AMERICAN NATIONAL STANDARDS FOR TREE CARE OPERATIONS, ANSI A300 INDUSTRY IDENTIFIED STANDARDS, IMPROPER OR MALICIOUS PRUNING TECHNIQUES ARE STRICTLY PROHIBITED.

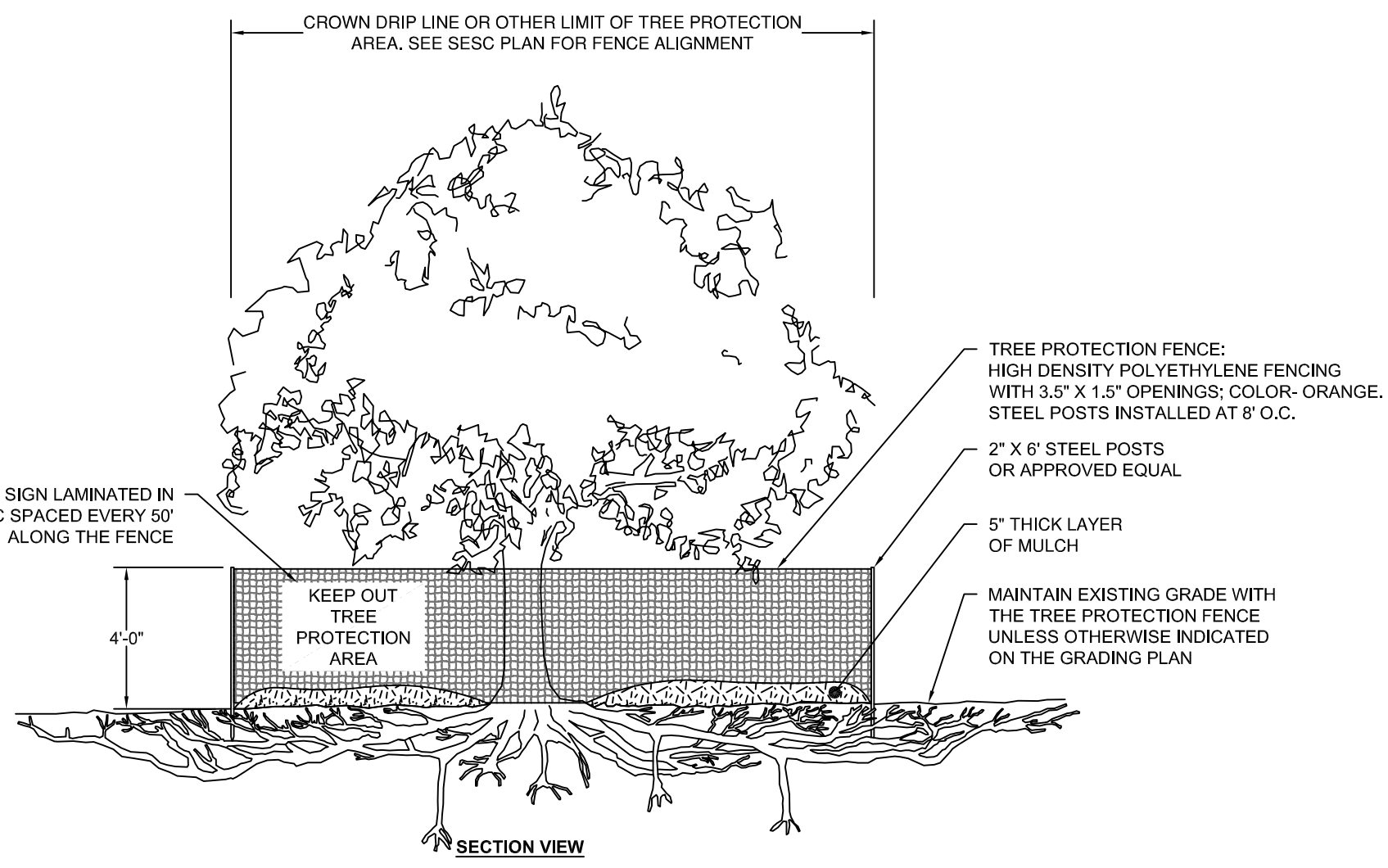
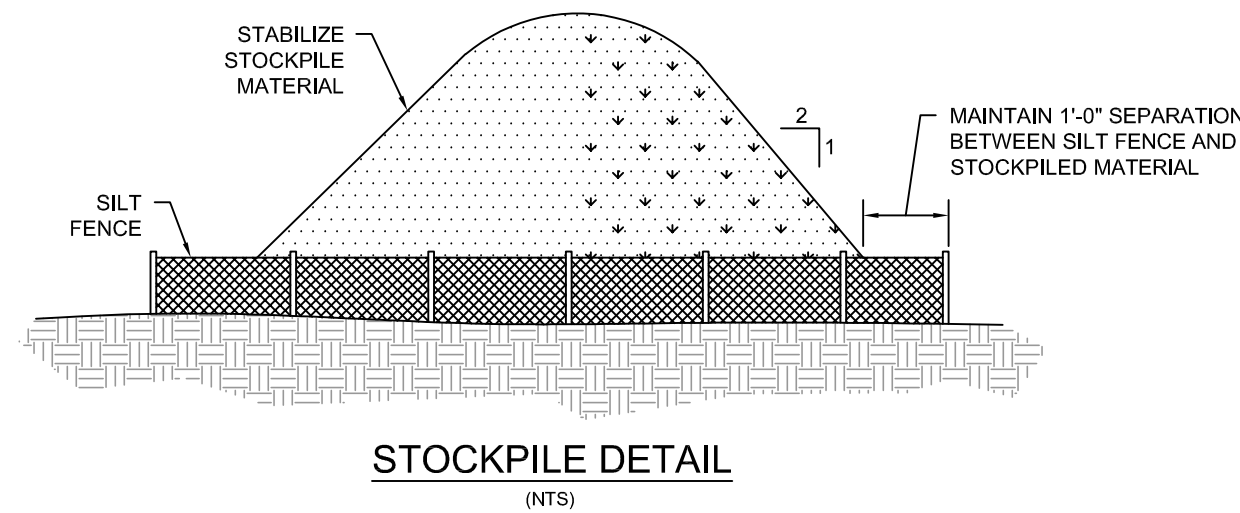
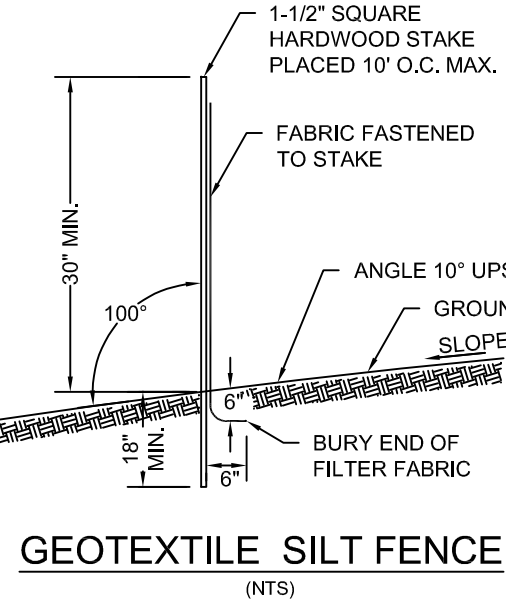

- NOTES:
1. NO PRUNING SHALL BE PERFORMED EXCEPT BY APPROVED ARBORIST.
2. NO EQUIPMENT SHALL OPERATE INSIDE THE PROTECTIVE FENCING INCLUDING DURING FENCE INSTALLATION AND REMOVAL.

TREE PROTECTION DETAIL (NTS)

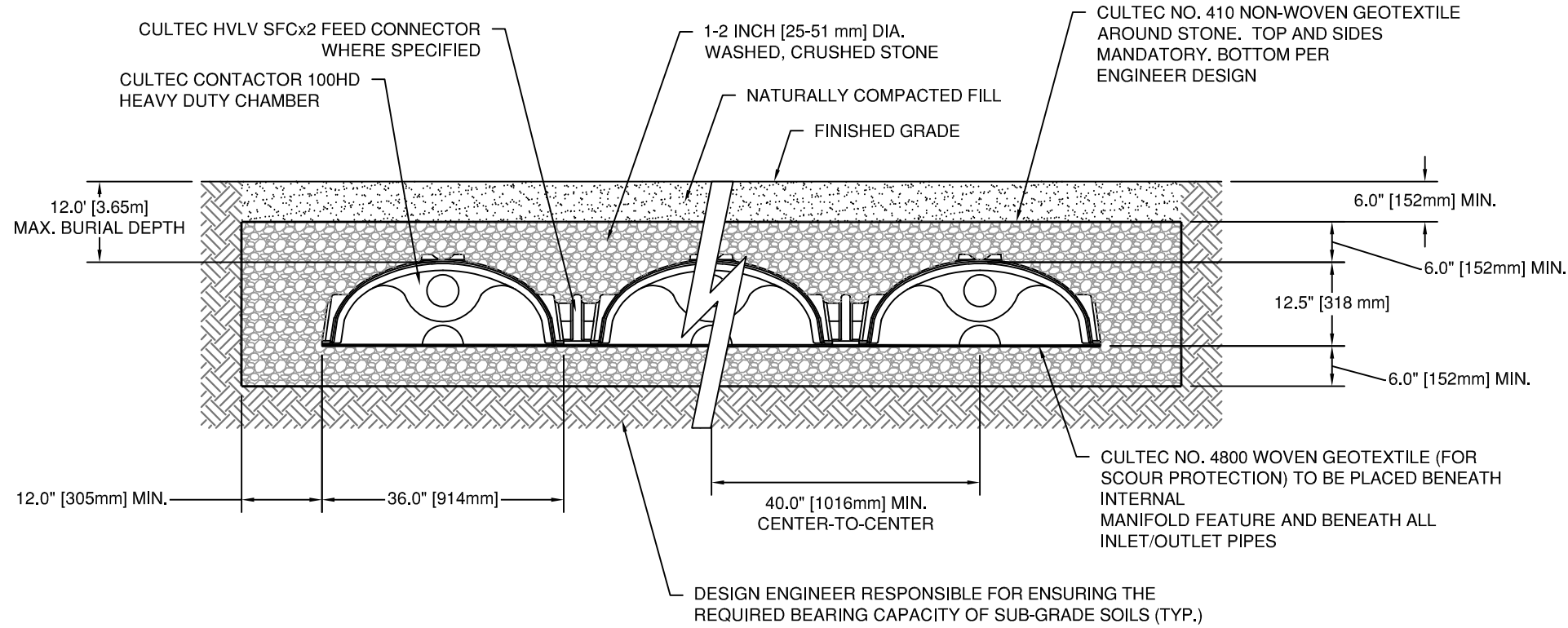

GENERAL NOTES
CONTRACTOR 100HD BY CULTEC, INC. OF BROOKFIELD, CT. STORAGE PROVIDED = 3.84 CF (0.82 M^3) PER DESIGN UNIT. REFER TO CULTEC, INC.'S CURRENT RECOMMENDED INSTALLATION GUIDELINES. MAXIMUM ALLOWED COVER ON TOP OF UNIT SHALL BE 12.0' (3.66m) THE CHAMBER WILL BE DESIGNED TO WITHSTAND TRAFFIC LOADS.
WHEN INSTALLED ACCORDING TO CULTEC'S RECOMMENDED INSTALLATION INSTRUCTIONS, ALL CONTRACTOR 100HD HEAVY DUTY UNITS ARE MARKED WITH A COLOR STRIPE FORMED INTO THE PART ALONG THE LENGTH OF THE CHAMBER. ALL CONTRACTOR 100 CHAMBERS MUST BE INSTALLED IN ACCORDANCE WITH ALL APPLICABLE LOCAL, STATE AND FEDERAL REGULATIONS.

CULTEC CONTACTOR 100HD HEAVY DUTY (NON-TRAFFIC APP.) TYPICAL CROSS SECTION (NTS)

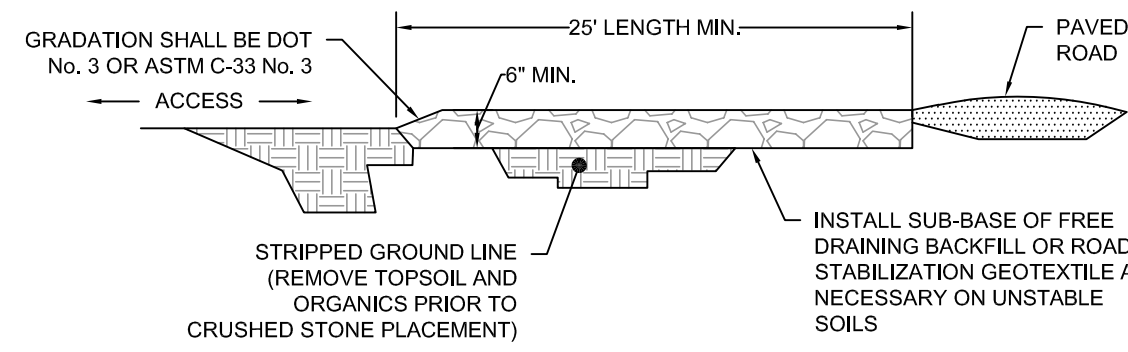

CONSTRUCTION ENTRANCE (NTS)

TEST HOLE DATA

SOIL TEST CONDUCTED ON MARCH 14, 2024

TEST HOLE 1

Table with 2 columns: Depth (0-10, 10-68) and Description (Topsoil, Orange Brown Sandy Loam, Roots to 45', Mottling @ 30', Groundwater @ 68', No Ledge, Restrictive Layer @ 30')

TEST HOLE 2

Table with 2 columns: Depth (0-11, 11-48, 48-72) and Description (Topsoil, Orange Brown Sandy Loam, Grey Sandy Loam, Roots to 45', Mottling @ 36', Groundwater @ 64', No Ledge, Restrictive Layer @ 26')

TEST HOLE 3

Table with 2 columns: Depth (0-11, 11-40, 48-73) and Description (Topsoil, Orange Brown Sandy Loam, Grey Sandy Loam, Roots to 26', Mottling @ 26', Groundwater @ 71', No Ledge, Restrictive Layer @ 26')

TEST HOLE 4

Table with 2 columns: Depth (0-12, 12-36, 36-67) and Description (Topsoil, Orange Brown Sandy Loam, Grey Sandy Loam, Roots to 21', Mottling @ 36', Groundwater @ 64', No Ledge, Restrictive Layer @ 36')

PERCOLATION TEST DATA

Table showing Percolation Test Data for Perc Hole 1. Columns: Time, Depth, Drop, Interval, Rate. Final Rate: 1 inch in 10.00 minutes.

PERCOLATION TEST DATA

Table showing Percolation Test Data for Perc Hole 2. Columns: Time, Depth, Drop, Interval, Rate. Final Rate: 1 inch in 10.00 minutes.

Soil Tests Conducted on July 31, 2015

Test Hole 1

Table showing Soil Test Results for Test Hole 1. Columns: Depth, Description (Topsoil, Red brown fine sandy loam, Olive brown stony fine sandy loam, Roots to 39', No Mottling, No G.W., No Ledge).

Test Hole 2

Table showing Soil Test Results for Test Hole 2. Columns: Depth, Description (Topsoil, Red brown fine sandy loam, Olive brown stony fine sandy loam, Roots to 38', No Mottling, No G.W., No Ledge).

Test Hole 3

Table showing Soil Test Results for Test Hole 3. Columns: Depth, Description (Topsoil, Red brown fine sandy loam, Olive brown stony fine sandy loam, No Mottling, No G.W., No Ledge).

Perc Hole P-1 Date: 7/31/2015
Depth: 24 in. Pre-soak: 8.45

Table showing Percolation Test Data for Perc Hole P-1. Columns: Time, Depth, Drop, Interval, Rate.

Perc Hole P-2 Date: 11/30/2016
Depth: 36 in.

Table showing Percolation Test Data for Perc Hole P-2. Columns: Time, Depth, Drop, Interval, Rate.

Final Rate: 1 inch in 4.44 minutes

Revision table with columns: Revision Date, Issue. Includes dates 8/11/2024, 8/30/2024, 7/8/2024 and corresponding issues like 'REVISED COVERAGE CHART', 'REVISED PER AHD COMMENTS', 'REVISED TO SHOW WPLO LINE'.

LANDTECH logo and contact information: SITE/CIVIL • ENVIRONMENTAL • SURVEYING • PLANNING, 518 RIVERSIDE AVENUE, WESTPORT, CT 06880, 203-454-2110.

PREPARED FOR: WAKEMAN TOWN FARM
PROJECT LOCATION: 134 CROSS HIGHWAY WESTPORT CT

PROJECT TITLE: SITE IMPROVEMENTS FOR A PROPOSED BARN ADDITION

NOTES AND DETAILS

PROJECT No: 24084-01
DATE: 6/12/2024 DESIGNED BY: RW CHECKED BY: AS
SCALE: N.T.S.

PROJECT STATUS: DESIGN DEVELOPMENT NOT FOR CONSTRUCTION

Professional Engineer seal for State of Connecticut, License No. 27803, and the drawing number C-2.0.



**GENERAL SEPTIC NOTES**

- THE PROPOSED SEPTIC SYSTEM IS TO BE CONSTRUCTED TO CONFORM TO THE LATEST REVISION OF THE STATE OF CONNECTICUT PUBLIC HEALTH CODE.
- IT IS THE RESPONSIBILITY OF THE INSTALLER TO CALL "CALL BEFORE YOU DIG," 1-800-922-4455, TWO FULL WORKING DAYS PRIOR TO ANY EXCAVATION WORK ON THE PROPERTY.
- IT IS THE RESPONSIBILITY OF THE INSTALLER TO KEEP THE LOCAL HEALTH DEPARTMENT AND THE ENGINEER OF RECORD INFORMED OF CONSTRUCTION PROGRESS. NO DEVIATIONS FROM THE APPROVED DESIGN PLAN SHALL BE ALLOWED WITHOUT THE PRIOR APPROVAL OF THE ENGINEER AND SANITARIAN. ENGINEER AND SANITARIAN WILL BE CONTACTED IF SOIL CONDITIONS OTHER THAN THOSE SHOWN ON PLAN ARE ENCOUNTERED AND WORK WILL BE HALTED PENDING REVIEW OF THOSE CONDITIONS.
- THE INSTALLATION OF THE SEPTIC SYSTEM SHALL BE UNDER THE SUPERVISION OF A PROFESSIONAL ENGINEER.
- ELEVATIONS SHOWN REFER TO THE INVERT (FLOW LINE) OF THE PROPOSED LEACHING SYSTEM UNLESS NOTED OTHERWISE.
- UTILIZATION OF EXISTING SEPTIC TANK WILL BE BASED UPON THE INTEGRITY OF THE TANK AND BAFFLES DETERMINED PRIOR TO LEACHING SYSTEM CONSTRUCTION.
- PROVIDE A 1,000 GALLON, TWO COMPARTMENT SEPTIC TANK MADE OF CONCRETE WITH A MINIMUM 4,000 PSI CONCRETE PER ASTM STANDARDS. SEPTIC TANK ACCESS SHALL BE OUTFITTED WITH 24" DIAMETER RISERS TO FINISHED GRADE WHERE SOIL COVER OVER THE TANK EXCEEDS 12 INCHES. SEAL ALL JOINTS WATER TIGHT. ALL TANK INLET AND OUTLET PIPING SHALL BE SEALED WITH A POLYETHYLENE GASKET, "POLYLOK" OR EQUIVALENT. TANK TO BE WATER TIGHT.
- ALL RISER ASSEMBLIES UTILIZED SHALL BE EQUIPPED WITH SECONDARY SAFETY LIDS OR DEVICES EVEN IF THE RISER COVER WEIGHS MORE THAN 50 LBS. SECONDARY SAFETY DEVICES SHALL BE IN ACCORDANCE WITH THE STATE OF CONNECTICUT PUBLIC HEALTH CODE, LATEST REVISION.
- SEPTIC TANK BAFFLES SHALL CONFORM TO TECHNICAL STANDARDS OF THE PUBLIC HEALTH CODE.
- SEPTIC TANK SHALL HAVE AN APPROVED NON-BYPASS EFFLUENT FILTER AT THE OUTLET.
- ALL PIPING BETWEEN BARN AND SEPTIC TANK SHALL BE FOUR INCHES IN DIAMETER WITH A MINIMUM SLOPE OF 1/8" PER FOOT OR SIX INCHES IN DIAMETER WITH A MINIMUM SLOPE OF 1/4" PER FOOT. PIPE SHALL BE LAID WITH TIGHT JOINTS AND IN A STRAIGHT LINE WITH UNIFORM GRADES. ACCESSIBLE MANHOLES OR SURFACE CLEANOUTS SHALL BE PROVIDED AT ONE OR MORE CUMULATIVE CHANGES OF DIRECTION EXCEEDING 45 DEGREES OR WHERE BUILDING SEWER EXCEEDS 75 FEET IN LENGTH. MATERIALS TO BE ALLOWED BY TECHNICAL STANDARDS.
- ALL PIPE USED BETWEEN SEPTIC TANK AND LEACHING AREA SHALL BE 4" SDR-35 PVC PIPE WITH WATER TIGHT JOINTS OR EQUIVALENT ALLOWED BY TECHNICAL STANDARDS. PIPE SHALL BE SET ON A MINIMUM SLOPE OF 1/8" PER FOOT.
- DISTRIBUTION BOXES ARE TO BE SET ON A STABLE FOOTING OF 12" MINIMUM DEPTH OF 1" CRUSHED STONE.
- ALL FILTER FABRIC SHALL BE 1.5 OZ./YD. (ASTM D-5261), PERMEABILITY OF 1.0/SEC. (AS TM D-4491) AND A TRAPEZOID TEAR OF 15 LBS. (ASTM D-4533) OR EQUIVALENT.
- NO FOOTING DRAINS OR OTHER GROUNDWATER DRAINS SHALL BE INSTALLED WITHIN 25' OF PROPOSED SEPTIC SYSTEM OR WITHIN 50 FEET OF SEPTIC SYSTEM IF DRAIN IS DOWN GRADIENT.
- PRIOR TO CONSTRUCTION ACTIVITIES THE LEACHING SYSTEM AREAS SHALL BE ROPED OFF OR OTHERWISE DELINEATED SO AS TO KEEP CONSTRUCTION TRAFFIC OFF THE SEPTIC AREA.
- STRIP AND STOCKPILE TOPSOIL AND REMOVE BOULDERS PRIOR TO PLACING FILL. ALL TOPSOIL MUST BE REMOVED IN FILL SYSTEMS.
- GRAVEL FILL TO BE DUMPED AT THE EDGE OF PREPARED LEACHING AREA AND PUSHED ONTO HARROWED SURFACE WITH TRACK MACHINE IN 12" (MAX) LIFTS. GRAVEL TO BE COMPACTED TO 90-95% STANDARD PROCTOR DENSITY - ASTM D-698. THE ENGINEER OF RECORD AND THE HEALTH DEPARTMENT MUST APPROVE THE SELECT GRAVEL PRIOR TO ITS PLACEMENT.
- SELECT FILL SHALL BE COMPRISED OF CLEAN SAND, OR SAND AND GRAVEL, FREE FROM ORGANIC MATTER AND FOREIGN SUBSTANCES. SELECT FILL SHALL MEET THE FOLLOWING REQUIREMENTS:
  - THE SELECT FILL SHALL NOT CONTAIN ANY MATERIAL LARGER THAN THE 3 INCH SIEVE.
  - UP TO 45% OF THE DRY WEIGHT OF THE REPRESENTATIVE SAMPLE MAY BE RETAINED ON THE #4 SIEVE.
  - THE MATERIAL THAT PASSES THE #4 SIEVE IS TO BE REWEIGHED AND A SECOND SIEVE ANALYSIS COMPLETED.
  - THE REMAINING SAMPLE SHALL MEET THE FOLLOWING GRADATION CRITERIA.
 

SIEVE SIZE	PERCENT PASSING	
	WET SIEVE	DRY SIEVE
#4	100	100
#10	70-100	70-100
#40	10-50*	10-75
#100	0-20	0-5
#200	0-5	0-2.5

 \*PERCENT PASSING THE #40 SIEVE CAN BE INCREASED TO NO GREATER THAN 75% IF THE PERCENT PASSING THE #100 SIEVE DOES NOT EXCEED 10% AND THE #200 SIEVE DOES NOT EXCEED 5%.
- NON-SELECT FILL SHALL BE A CLEAN LOAM OR BETTER FREE OF ORGANIC MATTER.
- THIS SYSTEM IS NOT DESIGNED FOR BACKWASH FROM A WATER SOFTENING SYSTEM OR THE OUTFLOW FROM A GARBAGE DISPOSAL OR TUB (BATHTUB, WHIRLPOOL, JACUZZI, ETC.) IN EXCESS OF 100 GALLONS.
- MEASUREMENTS FOR AS-BUILT DRAWING TO BE COMPLETED BY PROFESSIONAL ENGINEER PRIOR TO BACKFILLING.
- FINAL GRADING TO BE COMPLETED IMMEDIATELY AFTER INSPECTION AND COMPLETION OF MEASUREMENTS FOR AS-BUILT DRAWING.
- THERE ARE NO WELLS WITHIN 75' OF PROPOSED SEPTIC SYSTEM.
- THIS DESIGN CONFORMS TO APPLICABLE CODES AND ACCEPTED PRACTICE. NO OTHER WARRANTY IS EXPRESSED OR IMPLIED.
- LAND-TECH CONSULTANTS, INC., ASSUMES NO RESPONSIBILITY FOR SEPTIC SYSTEM SITE PREPARATION, LOCATION OR INVERT ELEVATIONS IN COMPLIANCE WITH THE APPROVED PLAN, UNLESS IT SUPERVISES EACH PHASE OF SYSTEM INSTALLATION.
- BASED ON A VISUAL INSPECTION OF NEIGHBORING PROPERTIES AND A REVIEW OF AVAILABLE RECORDS, NO PART OF THE PROPOSED SEPTIC SYSTEM IS WITHIN THE REQUIRED SEPARATION DISTANCE FROM A WATER SUPPLY WELL, OR CLOSED LOOP GEOTHERMAL SYSTEM BOREHOLE/TRENCH AS DEFINED IN TABLE 1 OF THE "TECHNICAL STANDARDS FOR SUBSURFACE SEWAGE DISPOSAL SYSTEMS", LATEST REVISION.

**SEPTIC SYSTEM DESIGN CALCULATIONS - BARN**

646.1 SF OF SUPERMARKET USE @ 0.1 GPD/SF (STORE / SEED ROOM)  
 20 PERSON OF DAY CAMP USE @ 15 GPD / PERSON (ACTIVITY ROOM)  
 646.1 SF X 0.1 GPD/SF + 20 PERSON \* 15 GPD/PERSON = 365 GPD  
 PERCOLATION RATE = 1 INCH @ 10.0 MINUTES USED FOR DESIGN (OBSERVED)  
 PERCOLATION RATE OF 1" IN LESS THAN 10.0 MINUTES)  
 SQUARE FEET OF LEACHING AREA REQUIRED = 365 DESIGN FLOW / 1.5 APPLICATION RATE = 243.3 SF (TABLE 8)  
 1000 GAL. SEPTIC TANK REQUIRED

PROPOSED SEPTIC SYSTEM LEACHING FIELD  
 45 LF OF 12" CONCRETE LEACHING GALLERIES  
 45 LF X 5.9 SF/LF = 265.5 SF OF LEACHING AREA PROVIDED  
 1000 GAL. SEPTIC TANK PROVIDED

PROPOSED RESERVE AREA  
 45 LF OF 12" CONCRETE LEACHING GALLERIES  
 45 LF X 5.9 SF/LF = 265.5 SF OF LEACHING AREA PROVIDED

**MLSS CALCULATION - BARN**  
 HYDRAULIC FACTOR (HF)  
 HYDRAULIC GRADIENT AT BOTH ENDS OF SYSTEM:  
 (204.7 - 202.0) / 66 = 4.1%; (204.4 - 202.5) / 66 = 2.9%  
 AVG. HYDRAULIC GRADIENT = (4.1 + 2.9) / 2 = 3.5%  
 HYDRAULIC GRADIENT = 3.1-4%

AVERAGE DEPTH OF TEST HOLES WITHIN THE SYSTEM:  
 DTH-1 = 30", DTH-2 = 26"  
 (30 + 26) / 2 = 28"  
 DEPTH OF DOWNGRADE TEST HOLE = DTH-3 = 26"  
 AVERAGE DEPTH OF RESTRICTIVE LAYER = (28 + 26) / 2 = 27"  
 HF = 34

FLOW FACTOR (FF):  
 DESIGN FLOW 365 GPD  
 FF = 1.22

PERCOLATION FACTOR (PF):  
 PERCOLATION RATE = 1" IN 10.1 - 20.0 MINUTES  
 PF = 1.0

MLSS = HF X FF X PF  
 MLSS = 34 X 1.22 X 1.0  
 MLSS = 41.5 FEET

PRIMARY LEACHING SYSTEM SPREAD = 45 FEET

**INVERT ELEVATIONS- BARN**

BUILDING SEWER AT FOUNDATION = 203.7 MIN.  
 SEPTIC TANK  
 INLET = 203.33  
 OUTLET = 203.0  
 PUMP CHAMBER  
 INLET 202.90  
 DISTRIBUTION BOX  
 INLET = 204.05  
 OUTLET = 204.00  
 LEACHING SYSTEM INVERT = 203.95  
 LEACHING SYSTEM BOTTOM = 203.53

**FLOW CALCULATION - EXISTING RESIDENCE**

Use	Occupancy	Comment	Design Flow*	Projected Sewage Flow(gpd)	Application Rate** (gpd/sf)	EA
4 Bedroom Dwelling	4 family members		TABLE 6	573.5	N/A	900.0
Commercial Kitchen	30	3-4/month,	1/3 gpd / meal served	50	0.8	62.5
Day Care- Mornings- 1 to 4 yr olds	30		10 gpd / pupil	300	1.5	66.7
Day Care- After school- 8 to 12 yr olds	21	No lunch prep	10 gpd / pupil	210	1.5	140.0
Summer Day Camp	40	6 weeks No food preparation	15 gpd / person	600	1.5	400.0
		<b>Total</b>		<b>1,528</b>		<b>1568.2</b>

\*Table 4 - Technical Standards  
 \*\*Tables 7 & 8 - Technical Standards (Assumes > 1"/10 min. percolation rate)

**SEPTIC SYSTEM DESIGN CALCULATIONS - EXISTING RESIDENCE**

1,580 GAL. SEPTIC TANK REQUIRED  
 2,000 GAL. SEPTIC TANK PROVIDED (EXISTING)

PROPOSED SEPTIC SYSTEM LEACHING FIELD  
 90 LF OF MANTIS DW-100 (45 LF EXISTING TO REMAIN, 45 LF PROPOSED)  
 90 LF X 20.0 SF/LF = 1,800 SF OF LEACHING AREA PROVIDED

**MLSS CALCULATION - EXISTING RESIDENCE**  
 RESTRICTIVE LAYER > 60 MLSS DOES NOT APPLY

**INVERT ELEVATIONS- EXISTING RESIDENCE**  
 DISTRIBUTION BOX (EXISTING)  
 INLET = 202.1  
 OUTLET = 202.0  
 EXISTING LEACHING SYSTEM INVERT = 201.90 (TO REMAIN)  
 EXISTING LEACHING SYSTEM BOTTOM = 200.90 (TO REMAIN)  
 PROPOSED LEACHING SYSTEM INVERT = 201.10  
 PROPOSED LEACHING SYSTEM BOTTOM = 200.10

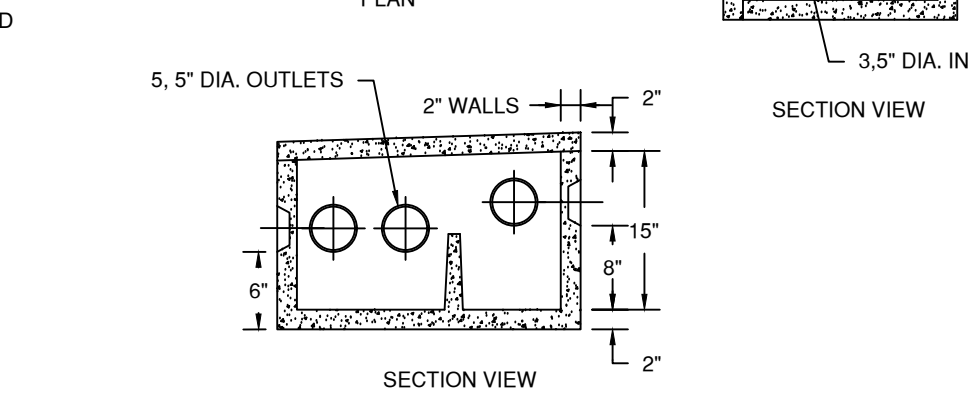
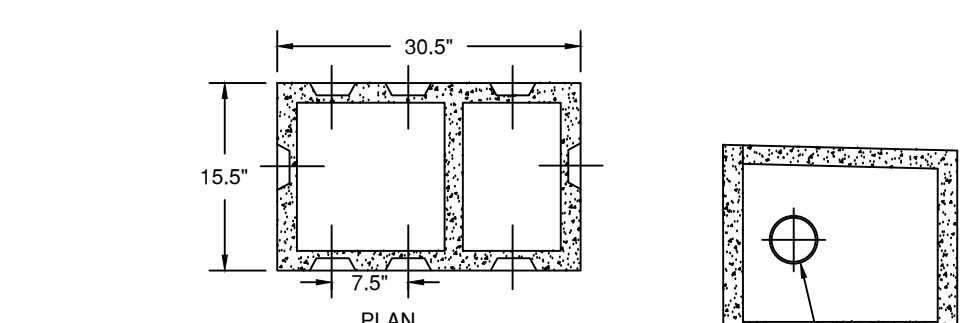

**DISTRIBUTION BOX WITH BAFFLE**  
(NTS)

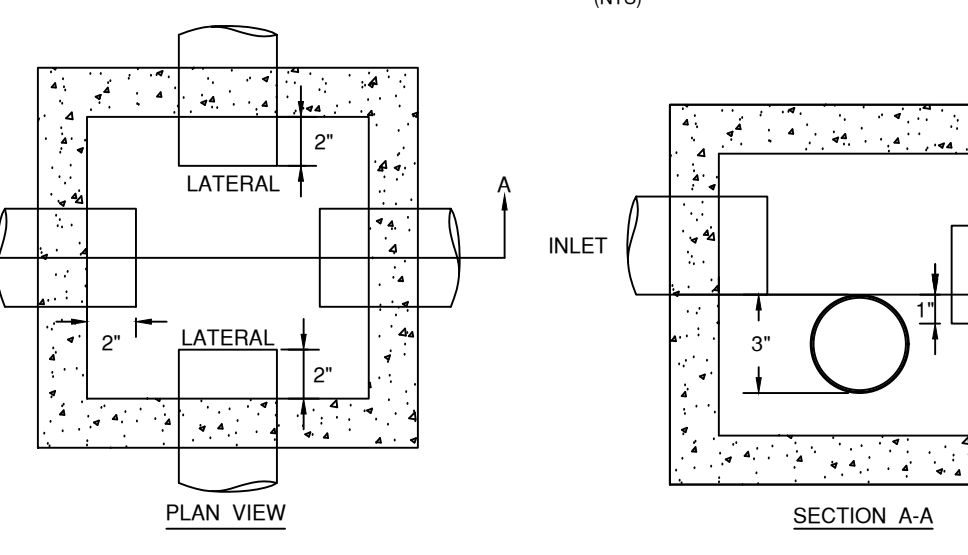

**HIGH LEVEL OVERFLOW (HLO) DISTRIBUTION BOX**  
(NTS)

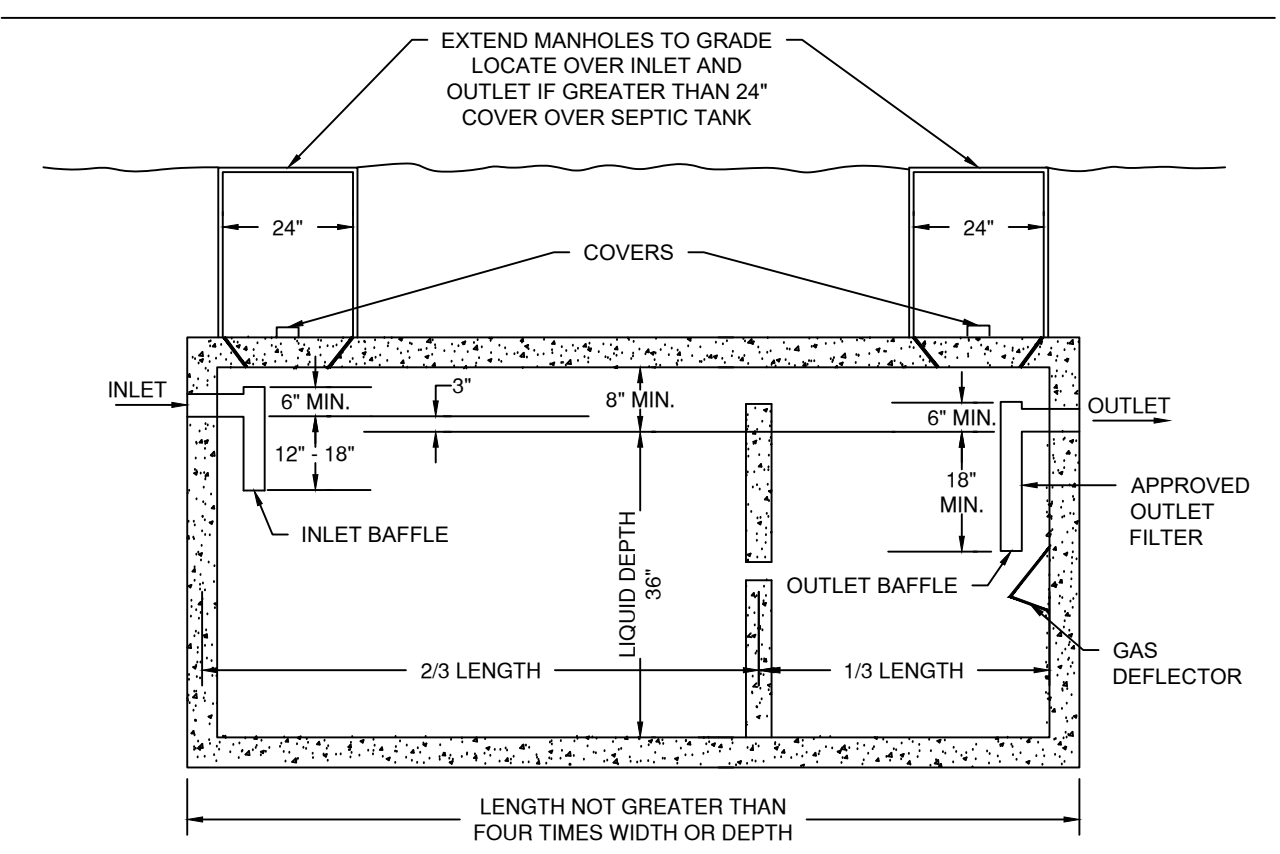

**SEPTIC TANK**  
(NTS)

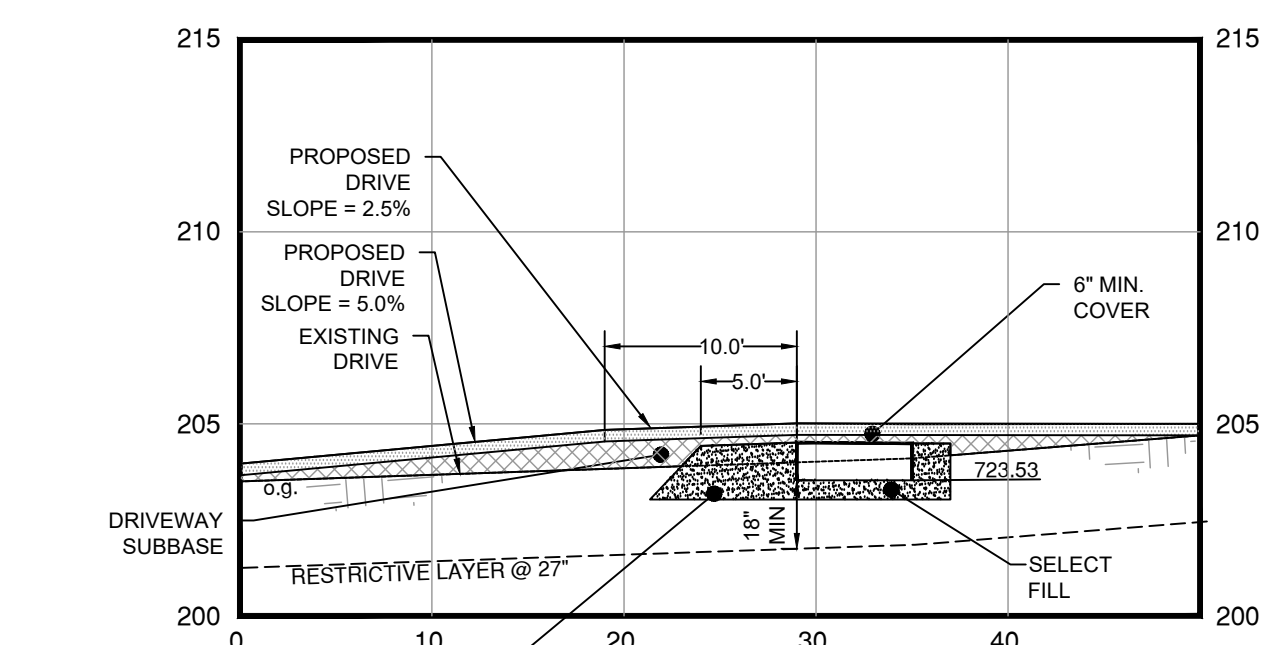

**SECTION A - A**  
SCALE: HORIZ. 1"=10'  
VERT. 1"=4'

REMOVE TOPSOIL AND REPLACE WITH SELECT FILL (SCARIFY SOIL PRIOR TO PLACEMENT OF SELECT FILL)

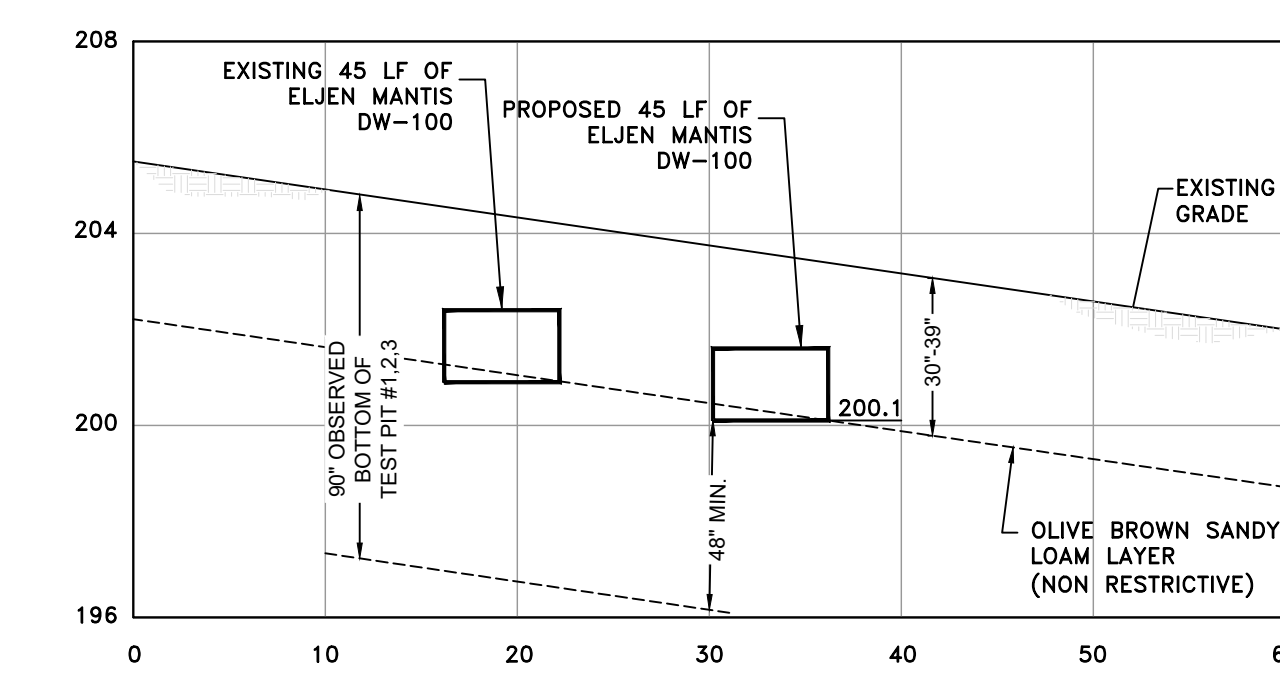

**SECTION B - B**  
HORIZONTAL 1"=10', VERTICAL 1"=4'

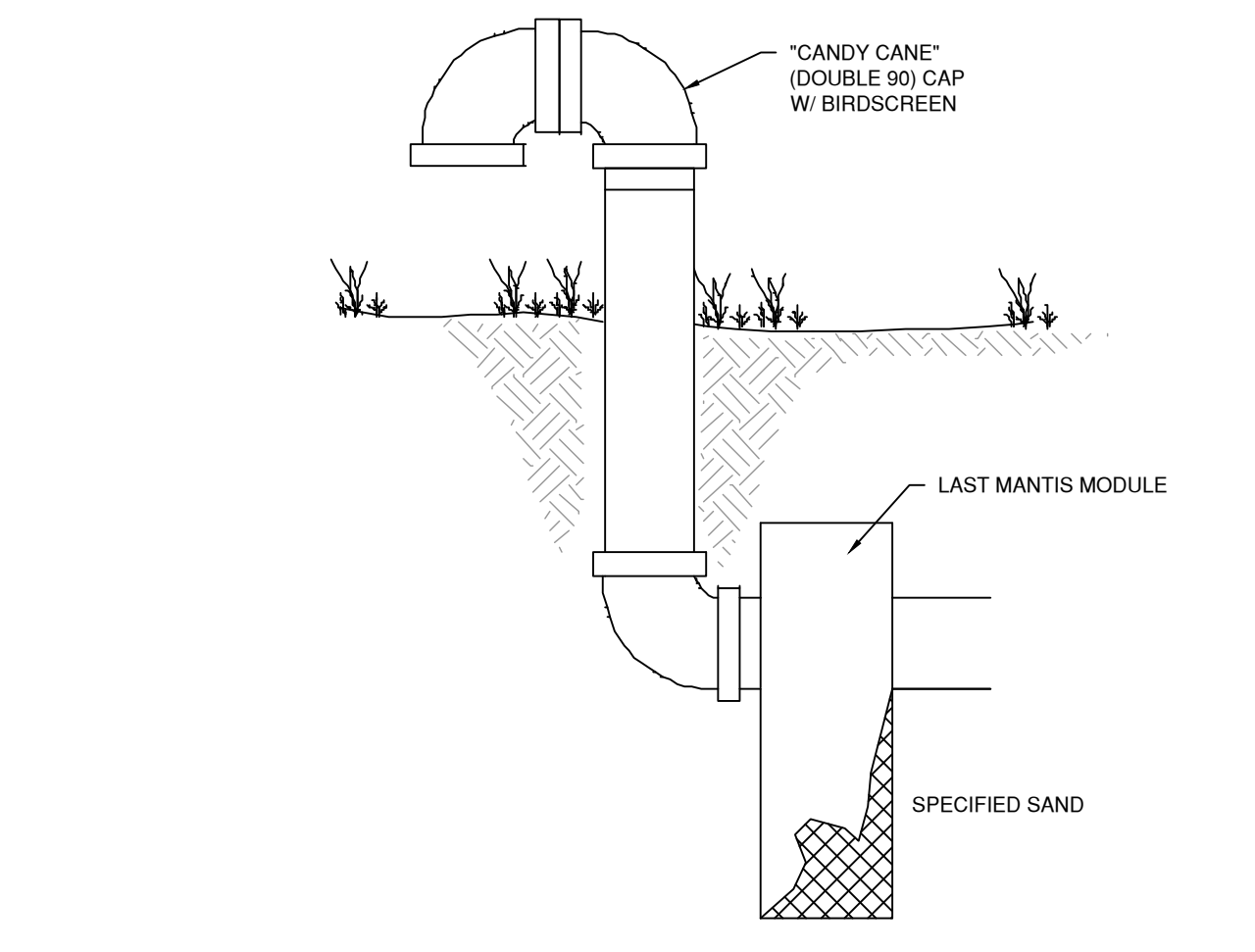

**MANTIS VENTING DETAIL - "CANDY CANE" TYPICAL SECTION**  
(NTS)

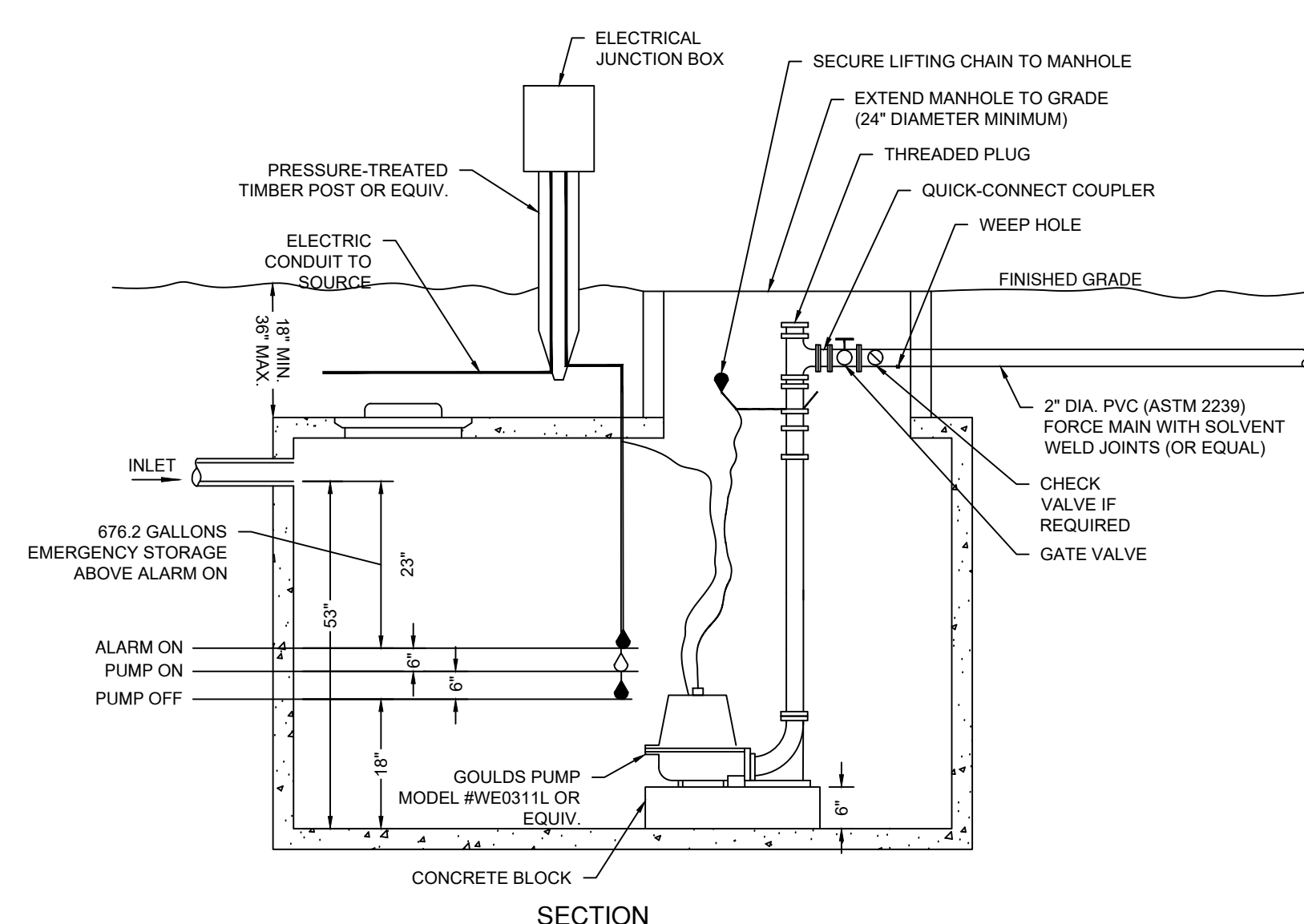
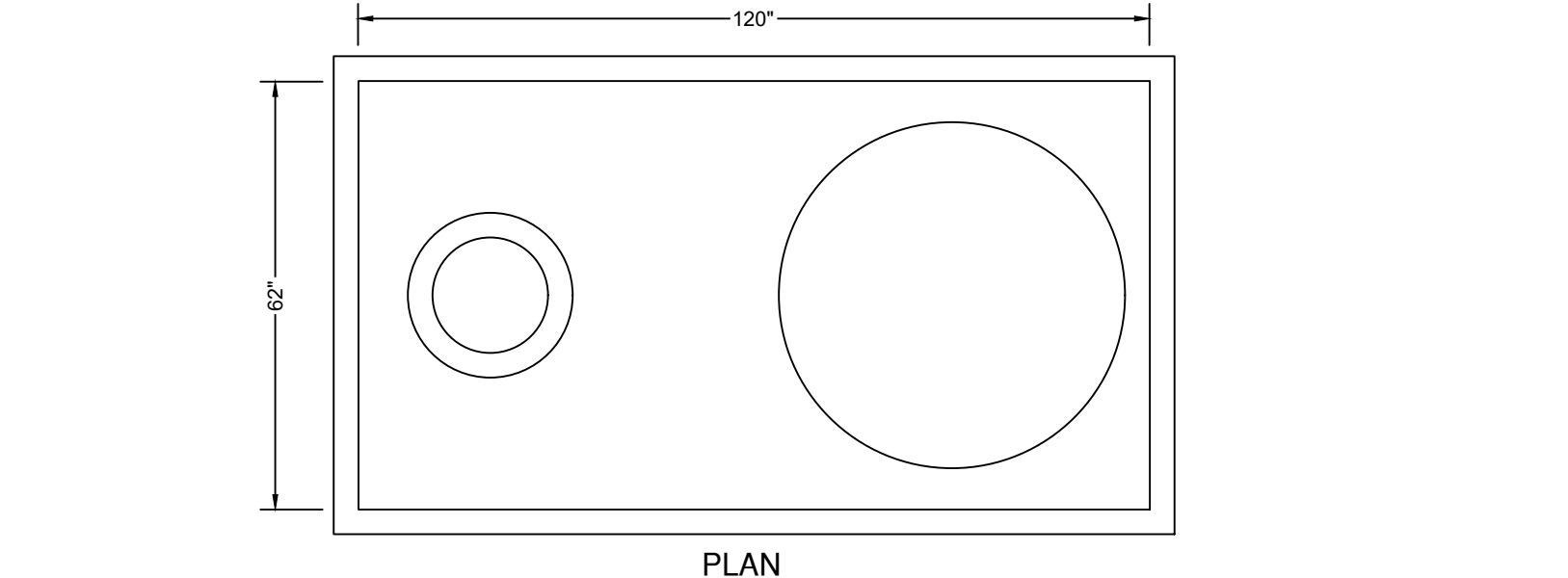

**1,000 GALLON PUMP CHAMBER**  
(NTS)

- GENERAL NOTES:**
- SET FLOATS TO PUMP 128.8 GALLONS PER CYCLE.
  - PUMP CHAMBER SHALL BE PRECAST CONCRETE AS MANUFACTURED BY CONNECTICUT PRECAST CORP. OR APPROVED EQUAL.
  - CONTRACTOR SHALL NOTIFY THE ENGINEER OF RECORD IF ALTERNATE MANUFACTURERS IS USED TO ADJUST FLOAT HEIGHTS ACCORDINGLY PRIOR TO INSTALLATION.

**12"x48" PRECAST CONCRETE GALLERY TYPICAL CROSS SECTION**  
(NTS)

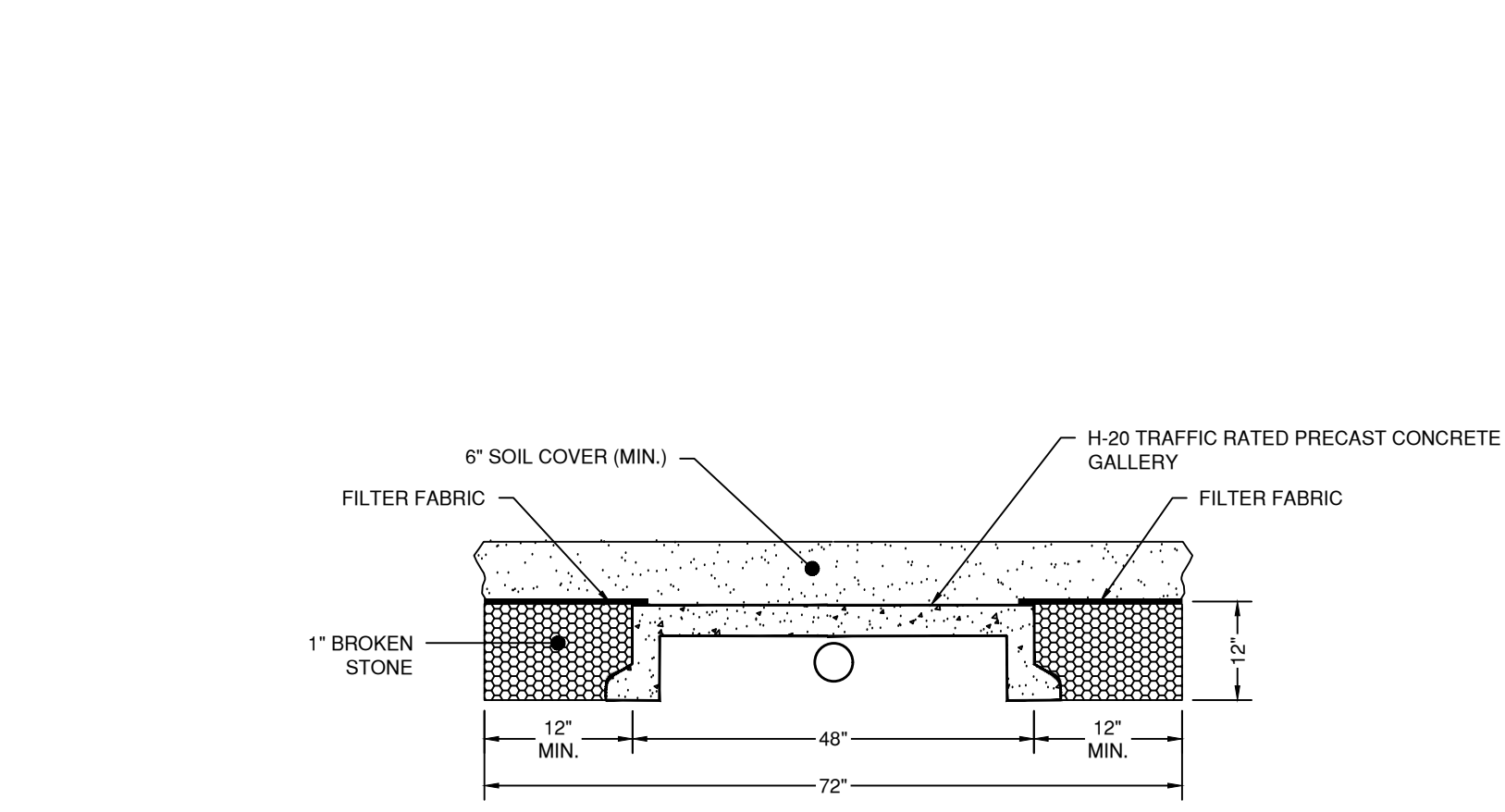

**12"x48" PRECAST CONCRETE GALLERY TYPICAL CROSS SECTION**  
(NTS)

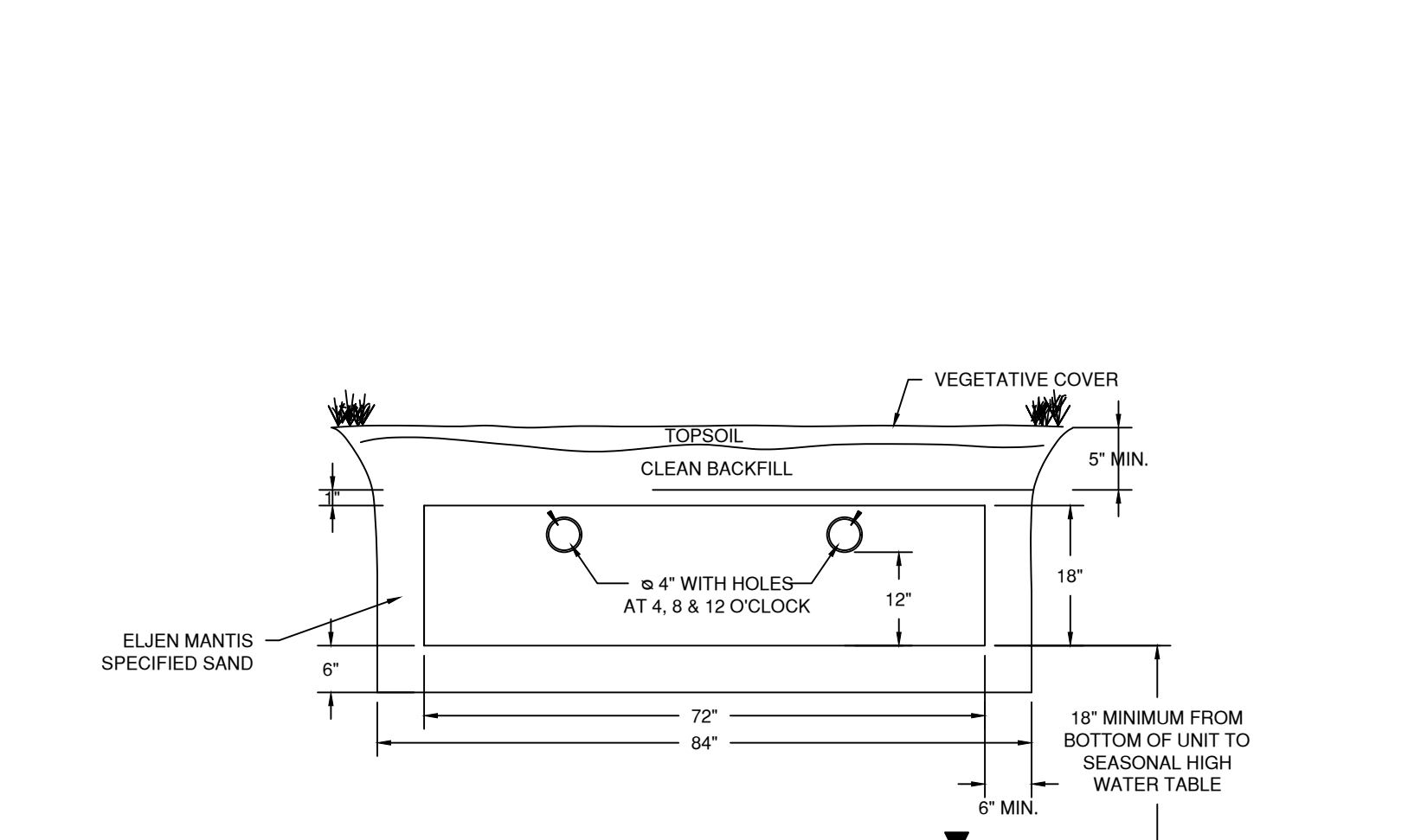

**ELJEN MANTIS DW-100 TYPICAL CROSS SECTION**  
(NTS)

NOTE: VENTING REQUIRED WHEN MORE THAN 18" OF COVER AS MEASURED FROM THE TOP OF THE UNIT TO FINISHED GRADE

9/11/2024	REVISED COVERAGE CHART
8/30/2024	REVISED PER AHD COMMENTS
7/8/2024	REVISED TO SHOW WP/LINE
REVISION DATE	ISSUE

**LANDTECH**  
 SITE/CIVIL • ENVIRONMENTAL • SURVEYING • PLANNING  
 518 RIVERSIDE AVENUE • WESTPORT, CT 06880 • 203-454-2110  
 HELLO@LANDTECHCONSULT.COM • WWW.LANDTECHCONSULT.COM

PREPARED FOR:  
**WAKEMAN TOWN FARM**

PROJECT LOCATION:  
**134 CROSS HIGHWAY  
 WESTPORT CT**

PROJECT TITLE:  
**SITE IMPROVEMENTS FOR A  
 PROPOSED BARN ADDITION**

DRAWING TITLE:  
**NOTES AND DETAILS**

PROJECT No. **24084-01**

DATE: **6/12/2024** DESIGNED BY: **RW** CHECKED BY: **AS**

SCALE: **N.T.S.**

PROJECT STATUS:  
**DESIGN DEVELOPMENT  
 NOT FOR CONSTRUCTION**

**C-3.0**