

| CURRENT OWNER            |  | TOPO        | UTILITIES      | STRT / ROAD | LOCATION   | CURRENT ASSESSMENT |       |           |          |
|--------------------------|--|-------------|----------------|-------------|------------|--------------------|-------|-----------|----------|
| EPURE STELIAN & CLAUDIA  |  |             | 3 Public Sewer | 2 Private   |            | Description        | Code  | Appraised | Assessed |
|                          |  |             | 2 Public Water |             |            | RES LAND           | 1-1   | 372,200   | 260,500  |
|                          |  |             |                |             |            | DWELLING           | 1-3   | 360,300   | 252,200  |
| <b>SUPPLEMENTAL DATA</b> |  |             |                |             |            |                    |       |           |          |
| 4 ROCKY RDG RD           |  | Alt Prcl ID | 5317173        |             | Lift Hse   |                    |       |           |          |
|                          |  | Historic ID |                |             | Asking \$  |                    |       |           |          |
|                          |  | Census      | 505            |             |            |                    |       |           |          |
|                          |  | WestportC   | H12            |             |            |                    |       |           |          |
|                          |  | Survey Ma   | 4290           |             |            |                    |       |           |          |
|                          |  | Survey Ma   |                |             |            |                    |       |           |          |
| WESTPORT CT 06880        |  | GIS ID      | D07102000      |             | Assoc Pid# |                    |       |           |          |
|                          |  |             |                |             |            |                    | Total | 732,500   | 512,700  |

6158  
 WESTPORT, CT  
**VISION**

| RECORD OF OWNERSHIP          |  |  | VOL/PAGE  | SALE DATE  | Q/U | V/I | SALE PRICE | VC | PREVIOUS ASSESSMENTS (HISTORY) |         |          |         |          |         |
|------------------------------|--|--|-----------|------------|-----|-----|------------|----|--------------------------------|---------|----------|---------|----------|---------|
| EPURE STELIAN & CLAUDIA      |  |  | 4129 0318 | 05-25-2021 | Q   | I   | 490,000    | 00 | Year                           | Code    | Assessed | Year    | Assessed |         |
| LUCCI SALVATORE D & MARTHA E |  |  | 1125 0222 | 11-04-1991 | Q   | I   | 150,000    | 00 | 2023                           | 1-1     | 260,500  | 2022    | 260,500  |         |
|                              |  |  |           |            |     |     |            |    | 1-3                            | 252,200 |          | 2021    | 260,500  |         |
|                              |  |  |           |            |     |     |            |    |                                |         |          |         | 52,400   |         |
|                              |  |  |           |            |     |     |            |    |                                | 512,700 | Total    | 312,900 | Total    | 312,900 |

| EXEMPTIONS                               |           |             | OTHER ASSESSMENTS |      |             |        | APPRAISED VALUE SUMMARY |                               |   |  |  |  |
|--|-----------|-------------|-------------------|------|-------------|--------|-------------------------|-------------------------------|---|--|--|--|
| Year                                     | Code      | Description | Amount            | Code | Description | Number | Amount                  | Comm Int                      | This signature acknowledges a visit by a Data Collector or Assessor |  |  |  |
|  |           |             |                   |      |             |        |                         |                               | Appraised Bldg. Value (Card)  |  |  |  |
| Total                                    |           |             | 0.00              |      |             |        |                         | 360,300                       |   |  |  |  |
| <b>ASSESSING NEIGHBORHOOD</b>            |           |             |                   |      |             |        |                         | Appraised Xf (B) Value (Bldg) |   |  |  |  |
|  |           |             |                   |      |             |        |                         | 0                             |   |  |  |  |
| Nbhd                                     | Nbhd Name |             | B                 |      | Tracing     |        | Batch                   |                               | Appraised Ob (B) Value (Bldg)                                       |  |  |  |
| 0002                                     | 0002      |             |                   |      |             |        |                         |                               | 0   |  |  |  |
| <b>NOTES</b>                             |           |             |                   |      |             |        |                         | Appraised Land Value (Bldg)   |   |  |  |  |
| M/ 4133(5 thru 8), 4290(B-1, rt of way t |           |             |                   |      |             |        |                         | 372,200                       |   |  |  |  |
| o Rocky Ri                               |           |             |                   |      |             |        |                         | Special Land Value            |   |  |  |  |
| 2015 LOT HAS ROCK LEDGE                  |           |             |                   |      |             |        |                         | 0                             |   |  |  |  |
|  |           |             |                   |      |             |        |                         | Total Appraised Parcel Value  |   |  |  |  |
|  |           |             |                   |      |             |        |                         | 732,500                       |   |  |  |  |
|  |           |             |                   |      |             |        |                         | Valuation Method              |   |  |  |  |
|  |           |             |                   |      |             |        |                         | C                             |   |  |  |  |
|  |           |             |                   |      |             |        |                         | 732,500                       |   |  |  |  |
|  |           |             |                   |      |             |        |                         | Total Appraised Parcel Value  |   |  |  |  |

| BUILDING PERMIT RECORD |   |      |         |            |        |            |                         | VISIT / CHANGE HISTORY |     |      |    |    |                       |  |
|------------------------|---|------|---------|------------|--------|------------|-------------------------|------------------------|-----|------|----|----|-----------------------|--|
| Permit Id              | Issue Date  | Type | Amount  | Insp Date  | % Comp | Date Comp  | Comments                | Date                   | Id  | Type | Is | Cd | Purpost/Result        |  |
| BLD-2023-00944         | 04-20-2023  | DE   | 0       | 07-17-2023 | 100    | 07-17-2023 | DEMOLISH 1178 SF SINGLE | 09-28-2023             | BF  | 2    | 5  | 05 | Measur/New UC Under C |  |
| BLD-2023-00891         | 04-19-2023  | NC   | 900,000 | 09-28-2023 | 25     |            | TWO STORY SINGLE FAMILY | 03-23-2021             | PG  | 3    | 5  | 75 | REVIEWED N/C          |  |
|                        |   |      |         |            |        |            |                         | 05-19-2020             | SR  |      |    | 19 | Field Review          |  |
|                        |   |      |         |            |        |            |                         | 03-10-2016             | BAA |      |    | 50 | BAA Change            |  |
|                        |   |      |         |            |        |            |                         | 03-07-2016             | TM  | 6    |    | 55 | NOAH - Visual         |  |
| Permit Id              | Comments  |      |         |            |        |            |                         |                        |     |      |    |    |                       |  |
| BLD-2023-00944         | DEMOLISH 1178 SF SINGLE FAMILY DWELLING.  |      |         |            |        |            |                         |                        |     |      |    |    |                       |  |
| BLD-2023-00891         | TWO STORY SINGLE FAMILY DWELLING WITH FINISHED ATTIC, ON CRAWL SPACE, 4 BEDROOMS. |      |         |            |        |            |                         |                        |     |      |    |    |                       |  |

| LAND LINE VALUATION SECTION |          |                  |      |           |            |                        |          |            |       |       |           |                  |  |                     |            |            |
|-----------------------------|----------|------------------|------|-----------|------------|------------------------|----------|------------|-------|-------|-----------|------------------|--|---------------------|------------|------------|
| B                           | Use Code | Description      | Zone | Land Type | Land Units | Unit Price             | Size Adj | Site Index | Cond. | Nbhd. | Nbhd. Adj | Notes            |  | Location Adjustment | Adj Unit P | Land Value |
| 1                           | 101      | Single Family Re | A    |           | 0.640 AC   | 360,000.00             | 1.44236  | 5          | 0.80  | 140   | 1.400     | TOPO/LEDGE       |  | 1.0000              |            | 372,200    |
| Total Card Land Units       |          |                  |      |           | 0.640 AC   | Parcel Total Land Area |          |            |       |       | 0.640     | Total Land Value |  |                     |            | 372,200    |

| CONSTRUCTION DETAIL |      |                | CONSTRUCTION DETAIL (CONTINUED) |      |             |
|---------------------|------|----------------|---------------------------------|------|-------------|
| Element             | Cd   | Description    | Element                         | Cd   | Description |
| Style:              | 105  | Custom Design  | Fireplaces                      | 1    |             |
| Model               | 01   | Residential    | Ceiling Height                  | 9.00 |             |
| Grade:              | 16   | Type I         | Elevator                        |      |             |
| Stories:            | 2    | 1 Story        | <b>CONDO DATA</b>               |      |             |
| Occupancy           | 1    |                | Parcel Id                       |      | C           |
| Exterior Wall 1     | 14   | Wood Shingle   |                                 |      | Own         |
| Exterior Wall 2     |      |                |                                 |      | B           |
| Roof Structure:     | 03   | Gable          | Adjust Type                     | Code | Description |
| Roof Cover          | 03   | Asphalt Shingl |                                 |      | Factor%     |
| Interior Wall 1     | 05   | Drywall        | Condo Flr                       |      |             |
| Interior Wall 2     |      |                | Condo Unit                      |      |             |
| Interior Flr 1      | 12   | Hardwood       | <b>COST / MARKET VALUATION</b>  |      |             |
| Interior Flr 2      | 15   | Quarry Tile    | Building Value New              |      | 1,441,346   |
| Heat Fuel           | 03   | Gas            | Year Built                      |      | 2023        |
| Heat Type:          | 04   | Forced Air     | Effective Year Built            |      |             |
| AC Type:            | 03   | Central        | Depreciation Code               |      | A           |
| Total Bedrooms      | 04   | 4 Bedrooms     | Remodel Rating                  |      |             |
| Total Bthrms:       | 2    | 2 Full Baths   | Year Remodeled                  |      | 1           |
| Total Half Baths    | 1    | 1 Half Bath    | Depreciation %                  |      |             |
| Total Xtra Fixtrs   | 4    |                | Functional Obsol                |      |             |
| Total Rooms:        | 8    | 8 Rooms        | External Obsol                  |      |             |
| Bath Style:         | 03   | Modern         | Trend Factor                    |      | 1           |
| Kitchen Style:      | 03   | Modern         | Condition                       |      | UC          |
| Kitchens            | 1    |                | Condition %                     |      | 25          |
| Whirlpool Tubs      |      |                | Percent Good                    |      | 25          |
| Hot Tubs            |      |                | Cns Sect Rcnld                  |      | 360,300     |
| Sauna (SF Area)     |      |                | Dep % Ovr                       |      |             |
| Fin Basement        |      |                | Misc Imp Ovr                    |      |             |
| Fin Bsmt Qual       |      |                | Misc Imp Ovr Comment            |      |             |
| Bsmt. Garages       | 0    |                | Cost to Cure Ovr                |      |             |
| Interior Cond       | A    |                | Cost to Cure Ovr Comment        |      |             |
| Fireplaces          | 1    |                |                                 |      |             |
| Ceiling Height      | 9.00 |                |                                 |      |             |

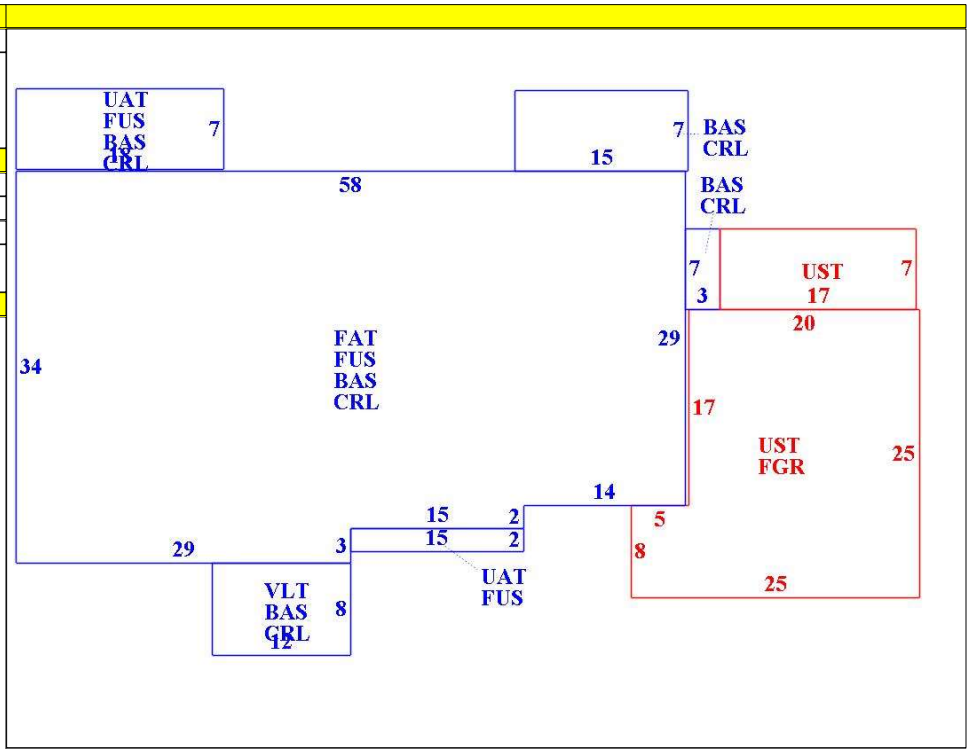

**OB - OUTBUILDING & YARD ITEMS(L) / XF - BUILDING EXTRA FEATURES(B)**

| Code | Description | L/B | Units | Unit Price | Yr Blt | Cond. Cd | % Gd | Grade | Grade Adj. | Appr. Value |
|------|-------------|-----|-------|------------|--------|----------|------|-------|------------|-------------|
|      |             |     |       |            |        |          |      |       |            |             |

**BUILDING SUB-AREA SUMMARY SECTION**

| Code                       | Description           | Living Area | Floor Area | Eff Area | Unit Cost | Undeprec Value |
|----------------------------|-----------------------|-------------|------------|----------|-----------|----------------|
| BAS                        | First Floor           | 2,205       | 2,205      |          | 268.98    | 593,108        |
| CRL                        | Crawl Space           | 0           | 2,205      |          | 0.00      | 0              |
| FAT                        | Attic, Finished       | 371         | 1,857      |          | 53.74     | 99,793         |
| FGR                        | Garage                | 0           | 540        |          | 107.59    | 58,100         |
| FUS                        | Upper Story, Finished | 2,013       | 2,013      |          | 268.98    | 541,463        |
| UAT                        | Attic, Unfinished     | 0           | 156        |          | 27.59     | 4,304          |
| UST                        | Utility, Storage      | 0           | 659        |          | 121.23    | 79,888         |
| VLT                        | Vaulted Ceiling       | 0           | 96         |          | 14.01     | 1,345          |
| Ttl Gross Liv / Lease Area |                       | 4,589       | 9,731      |          |           | 1,378,001      |

