

For Office Use Only:
Date of Filing: _____
Date of Public Hearing: _____
65 Day Period Ends: _____
Type of Work: _____

WESTPORT HISTORIC DISTRICT COMMISSION APPLICATION FOR CERTIFICATE OF APPROPRIATENESS (CA)

Application is hereby made for the issuance of a Certificate of Appropriateness under the Historic District Ordinance of Westport, Connecticut, enacted pursuant to the enabling authority contained in Chapter 97A, Section 7-147d and 147s, as amended, of the General Statutes of Connecticut.

RECEIVED

SECTION 1 (To be completed by the Applicant):

OCT 25 2022

Address of proposed work: 41 Wright St

HISTORIC DISTRICT
COMMISSION

Owner: Frank Zmuda

Phone: 917-623-7098

Email: fzmuda@gmail.com

Agent/Contractor: R. Wood Construction Co. LLC Robert C Wood TJ

Address: 49 Poplar Dr Shelton CT 06484

Phone: 203-395-2302

Email: woodythebuilder@gmail.com

Anticipated date of completion: 06/2023



10/21/22

Owner's Signature (Application must be signed)

Date

SECTION 2 (To be completed by the Zoning Enforcement Officer)

- Appears to comply with regulations
- Appears not to comply with regulations - Addn. appears to possibly be in setbacks, but no site plan submitted, fm
- More information needed

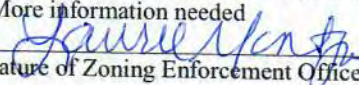

Signature of Zoning Enforcement Officer indicating preliminary review of compliance with zoning regulations.

SECTION 3 (To be completed by the Historic District Commission)

Date of Public Hearing: _____

- Certificate of Appropriateness APPROVED
List any conditions or modifications:

- Certificate of Appropriateness DENIED
List reasons for denial:

Signature/Chair, WHDC

Date

After approval has been obtained from the Historic District Commission, work cannot commence until proper zoning and building permits have been obtained from the Planning and Zoning and Building Departments.

SECTION 4 (To be completed by the Historic District Commission)

FINAL APPROVAL

Signature/WHDC: _____ Date of Site Inspection: _____



WESTPORT™

Historic District Commission

Town Hall, 110 Myrtle Avenue
Westport, CT 06880
Westportct.gov
Telephone (203) 341-1184

WESTPORT HISTORIC DISTRICT COMMISSION LEGAL NOTICE

Meeting ID: 891 8186 0473
Passcode: 735967
Dial by your location
+1 646 876 9923 US (New York)

Join Zoom Meeting

<https://us02web.zoom.us/j/89181860473?pwd=OUJmeHUvOWY4M0N1WFVJbmVwdVVnUT09>

The Westport Historic District Commission will hold an electronic public meeting at **7:00 p.m.** on **Wednesday, November 9, 2022**, for the following purposes:

1. To take such action as the meeting may determine to approve a *Certificate of Appropriateness* application dated October 21, 2022, for proposed restoration, renovation and two-story addition which will include a second garage bay, wood siding, trim, windows, doors, roofing, and shingles at **41 Wright Street** (PID # C09//043/000) which is located within the Kings Highway North Local Historic District: Kings Highway North National Historic District.

Bill Harris, Chair
Historic District Commission
October 26, 2022

Special Notice Regarding This Electronic Meeting:

There will be no physical location for this meeting. This meeting will be held electronically. Telephone and Zoom video participation details are above. Comments from the public will be received during the public meeting. A copy of the applications and Historic District Commission agenda for the meeting is available on-line at www.westportct.gov and on the Town Calendar web page under November 9, 2022.

It is the policy of the Town of Westport that all Town-sponsored public meetings and events are accessible to people with disabilities. If you need assistance in participating in a meeting or event due to a disability as defined under the Americans with Disabilities Act, please contact Westport's ADA Coordinator at 203-341-1043 or eflug@westportct.gov at least three (3) business days prior to the scheduled meeting or event to request an accommodation.

This is a narrative describing what our family intends to do with 41 Wright Street in Westport Connecticut. We are coming back to hdc with an amended plan... one which expands the home to have a second garage to allow that space to park plus a bit more space upstairs for the family. This plan remains within the setbacks both with the garage addition, and the slightly enlarged seasonal porch. We have the same intention of saving what we can and matching to the extent we can on both the areas being fixed and added. To maintain historic consistency.

We bought the John Clark house from Fred Clark who inherited the house from his mother and had grown up in it with his grandparents. This House has been in the Clark family since the early 1900s... and needs a lot of tlc.

We absolutely adore and love the home and are planning to return it to as much of its original splendor as possible. We are a family of seven and are planning on raising our family in this home... we have five children from ages of 6 to 13 currently and one of our families has been in Westport since 1950... so we are a big fans of Westport. We adore the hidden hamlets like old hill. We really appreciate the charm and character of the home and the history that is here.. our full plan is to rehabilitate it to the greatest extent possible while updating it to codes and a modern family lifestyle with size and materials that are as efficient as possible financially and realistically whilst remaining with the historic look.

We are so excited about being able to retain the original wooden floors and as much of the character of the home as possible... we have been working with structural engineers to be able to do so.. this house has such real craftsmanship.. everything we are doing is intended to match Marry and upgrade the beautiful elegant simplicity of this home. We're looking to maximize on space and keep costs reasonable because of our large family.. yet have plenty of room to navigate together.

We have provided spec sheets and material lists with the intention to hope to utilize modern materials that are being accepted in other historic districts recently which have the exact same look and historic shape yet require less cost for our family to maintain. Giving us the ability to afford bringing this home back to life.

As you know our main rooms remain of reasonable size and bedrooms are small/ reasonable.. the intention here is to have a place where a family can live in true appreciation of life in Westport... We hope you see that our plans come from our hearts and that we're really excited to create a place to raise our family on one of the best streets in town... the goal of this narrative is to let you all know that we're really excited to keep the home historic and update it within reason and affordability. Thank you kindly.
Frank and Caroline

REVISIONS



1 **EXISTING FRONT ELEVATION**
1/4"=1'-0"

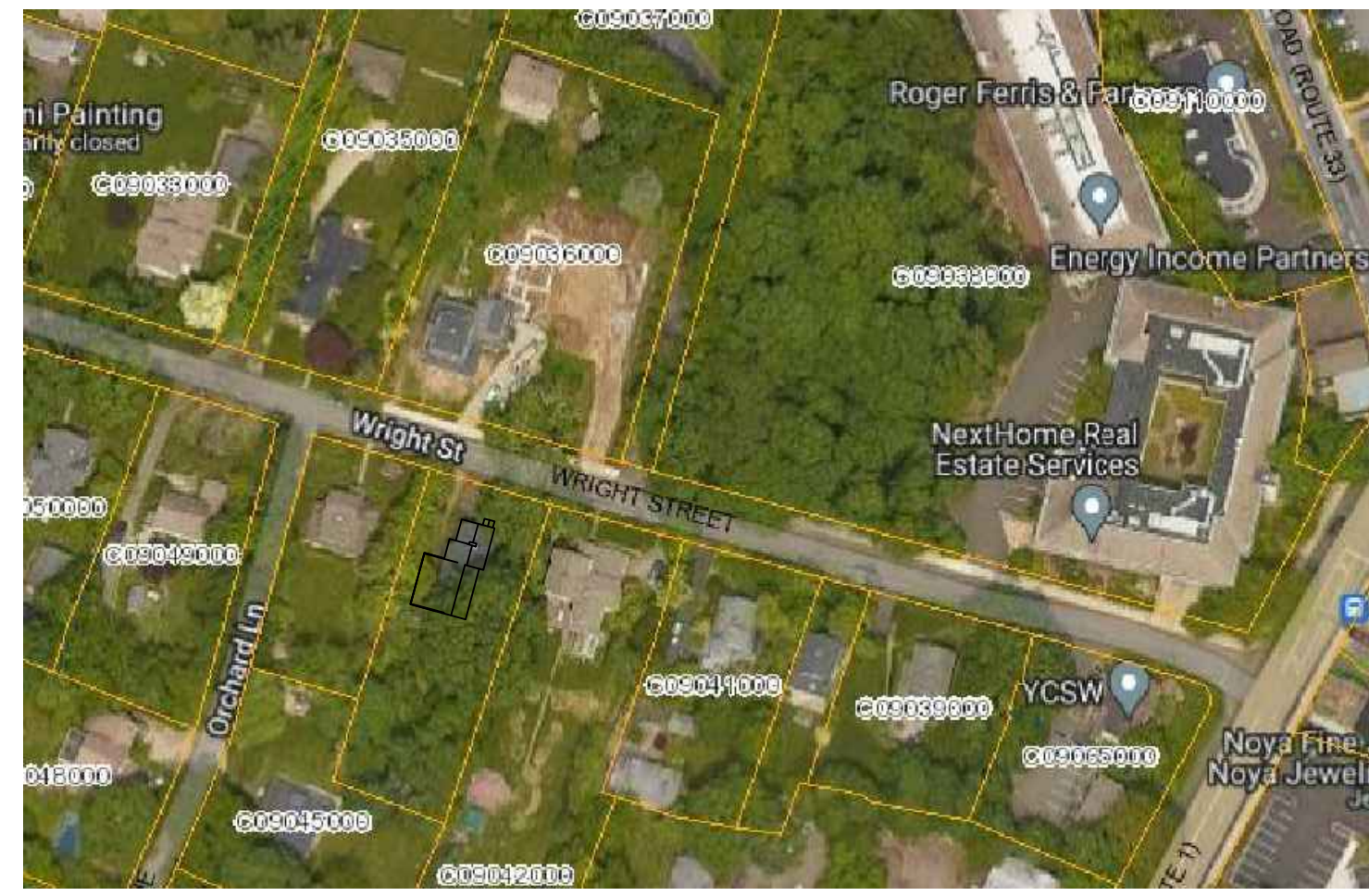

2 **PROPOSED FRONT ELEVATION**
1/4"=1'-0"

LEFORT ASSOCIATES
24 WARD LANE
STAMFORD, CT 06907
www.lefortassociates.com

ADDITION & RENOVATIONS:

FRANK ZMUDA

41 WRIGHT ROAD
WESTPORT, CT 06460

SCALE:
AS NOTED

DRAWN BY:
LEL

DATE:
2022 DECEMBER 1

PROJECT NO.
2216

PHASE PR
PR-1

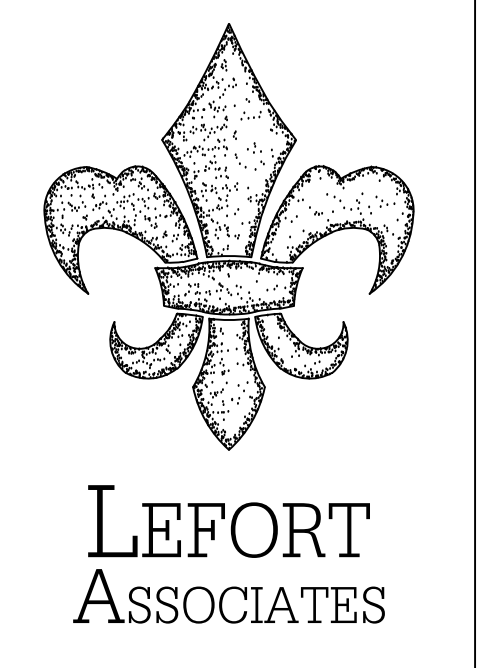

REVISIONS

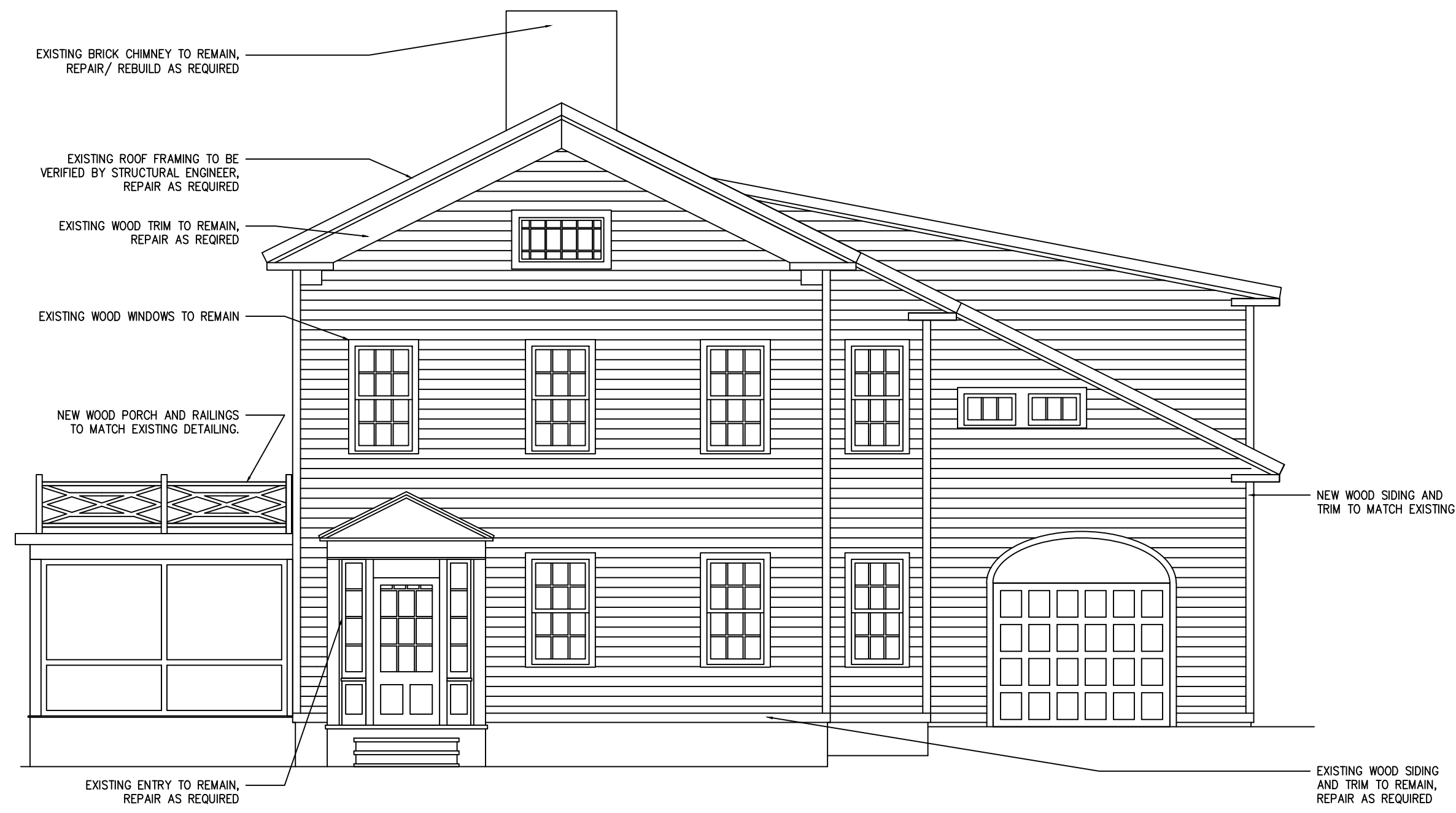

1 PROPOSED FRONT ELEVATION
3/16"=1'-0"



2 PROPOSED SIDE ELEVATION
3/16"=1'-0"



3 EXISTING FRONT ELEVATION
3/16"=1'-0"



4 EXISTING SIDE ELEVATION
3/16"=1'-0"

LEFORT ASSOCIATES
24 WARD LANE
STAMFORD, CT 06907
www.lefortassociates.com

ADDITION &
RENOVATIONS:

FRANK ZMUDA

41 WRIGHT ROAD
WESTPORT, CT 06460

SCALE:
AS NOTED

DRAWN BY:
LEL

DATE:
2022 DECEMBER 1

PROJECT NO.
2216

PHASE PR
PR-2

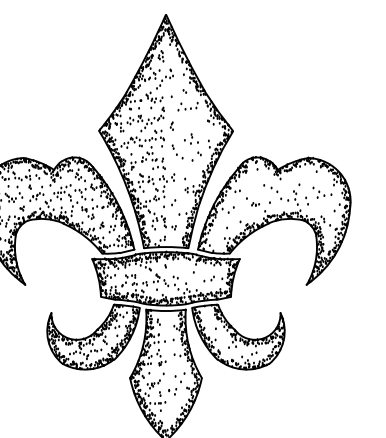

LEFORT
ASSOCIATES

REVISIONS



1 PROPOSED REAR ELEVATION
3/16"=1-0"



2 PROPOSED SIDE ELEVATION
3/16"=1-0"



3 EXISTING REAR ELEVATION
3/16"=1-0"



4 EXISTING SIDE ELEVATION
3/16"=1-0"

LEFORT ASSOCIATES
24 WARD LANE
STAMFORD, CT 06907
www.lefortassociates.com

ADDITION &
RENOVATIONS:

FRANK ZMUDA

41 WRIGHT ROAD
WESTPORT, CT 06460

SCALE:
AS NOTED

DRAWN BY:
LEL

DATE:
2022 DECEMBER 1

PROJECT NO.
2216

PHASE PR
PR-3

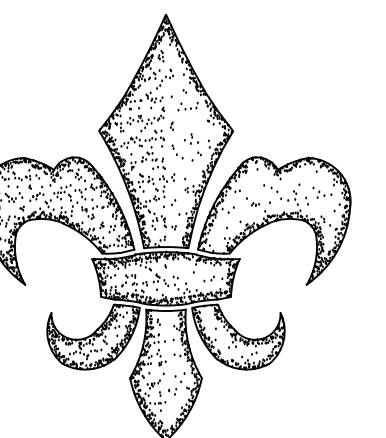

LEFORT
ASSOCIATES

REVISIONS

LEFORT ASSOCIATES
 24 WARD LANE
 STAMFORD, CT 06907
 www.lefortassociates.com

ADDITION & RENOVATIONS:

FRANK ZMUDA

41 WRIGHT ROAD
 WESTPORT, CT 06460

SCALE:
 AS NOTED

DRAWN BY:
 LEL

DATE:
 2022 DECEMBER 1

PROJECT NO.
 2216

PHASE PR
PR-4

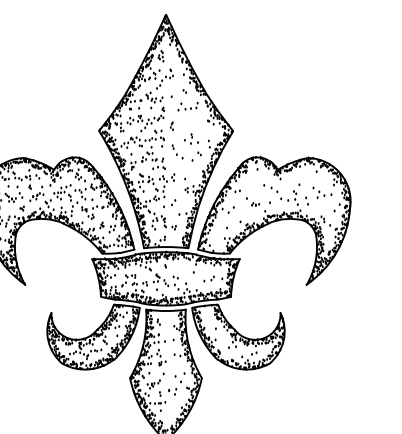

LEFORT ASSOCIATES

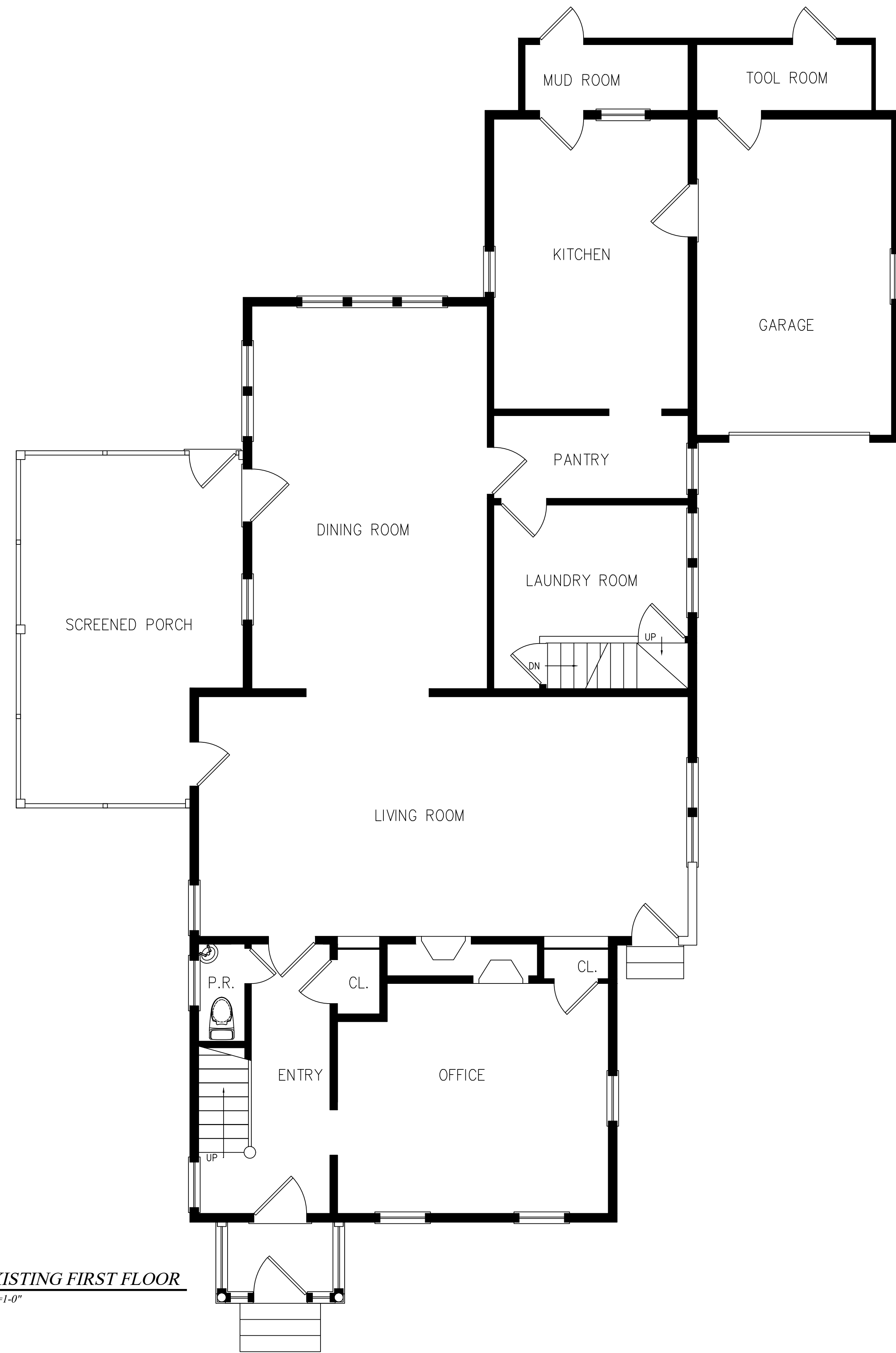

1 EXISTING FIRST FLOOR
 1/4"=1'-0"

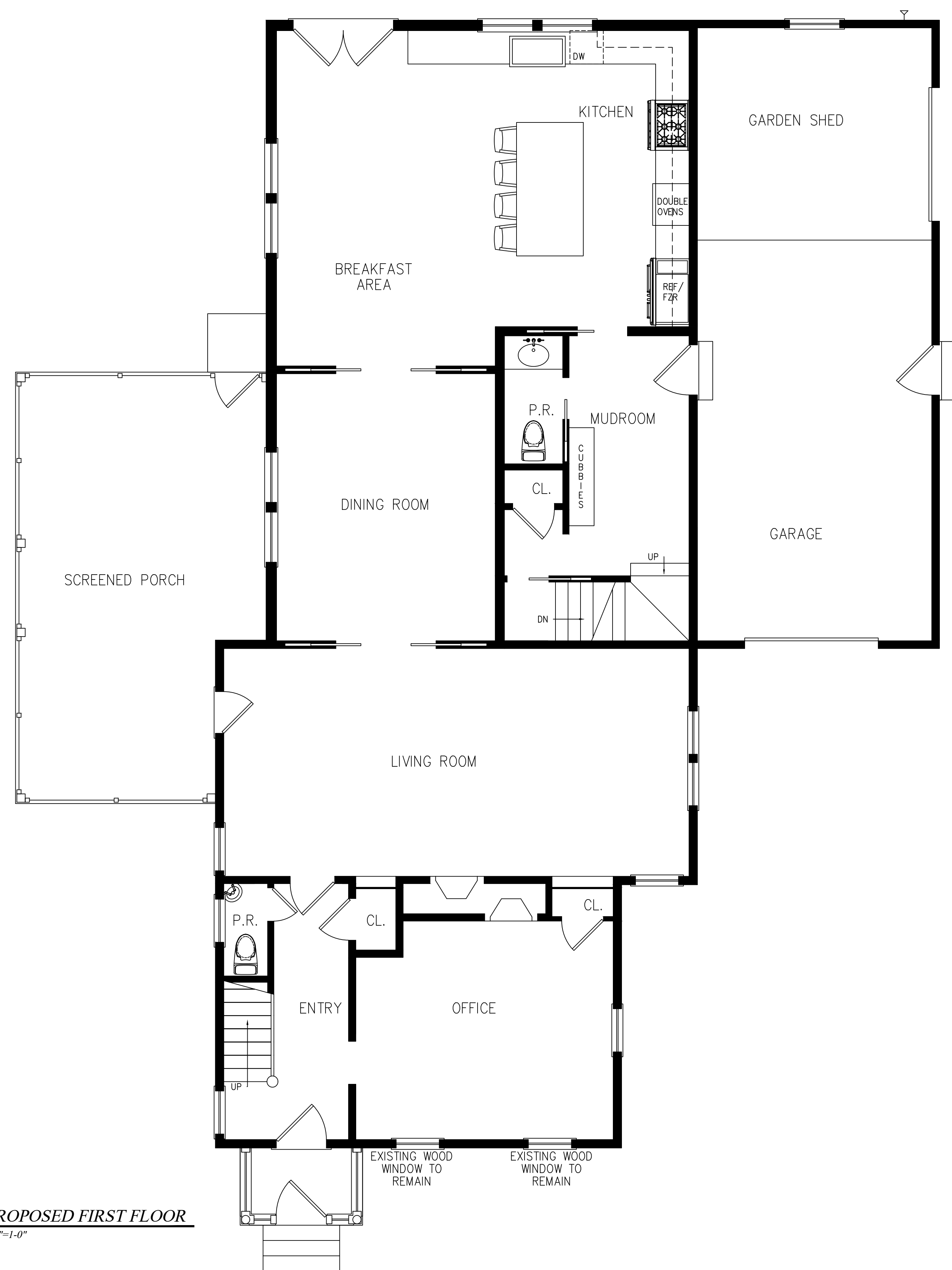

2 PROPOSED FIRST FLOOR
 1/4"=1'-0"

REVISIONS

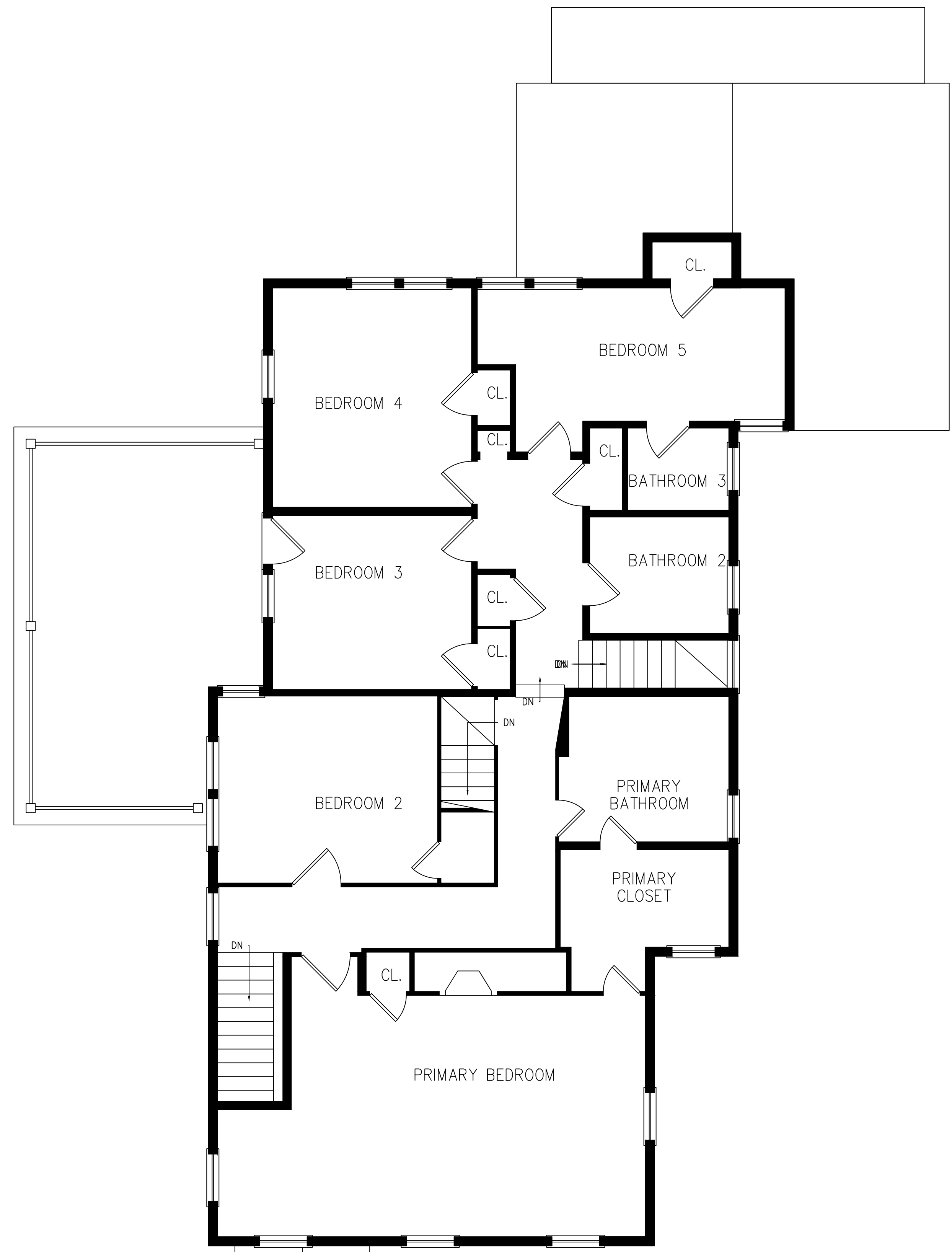

1 **EXISTING SECOND FLOOR**
1/4"=1'-0"

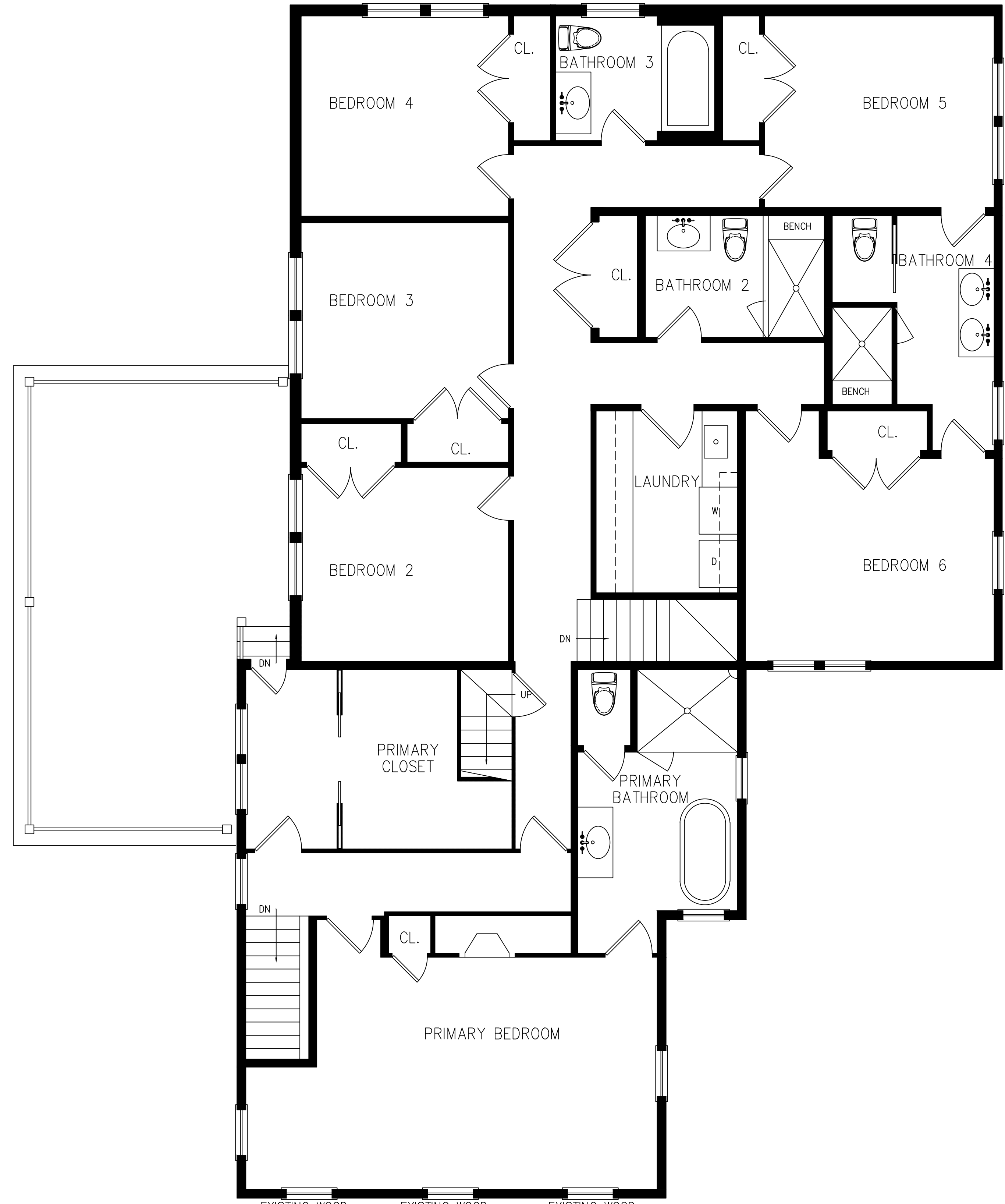

2 **PROPOSED SECOND FLOOR**
1/4"=1'-0"

LEFORT ASSOCIATES
24 WARD LANE
STAMFORD, CT 06907
www.lefortassociates.com

ADDITION & RENOVATIONS:

FRANK ZMUDA

41 WRIGHT ROAD
WESTPORT, CT 06460

SCALE:
AS NOTED

DRAWN BY:
LEL

DATE:
2022 DECEMBER 1

PROJECT NO.
2216

PHASE PR
PR-5

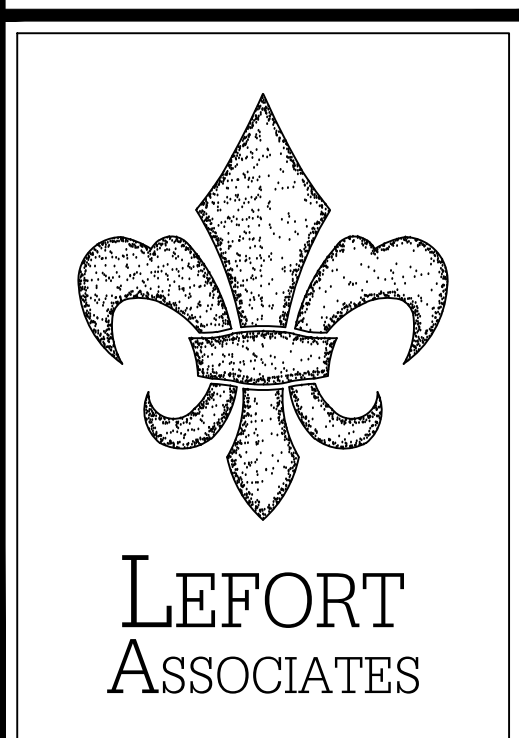

REVISIONS



EXISTING



PROPOSED



PROPOSED APPROVED

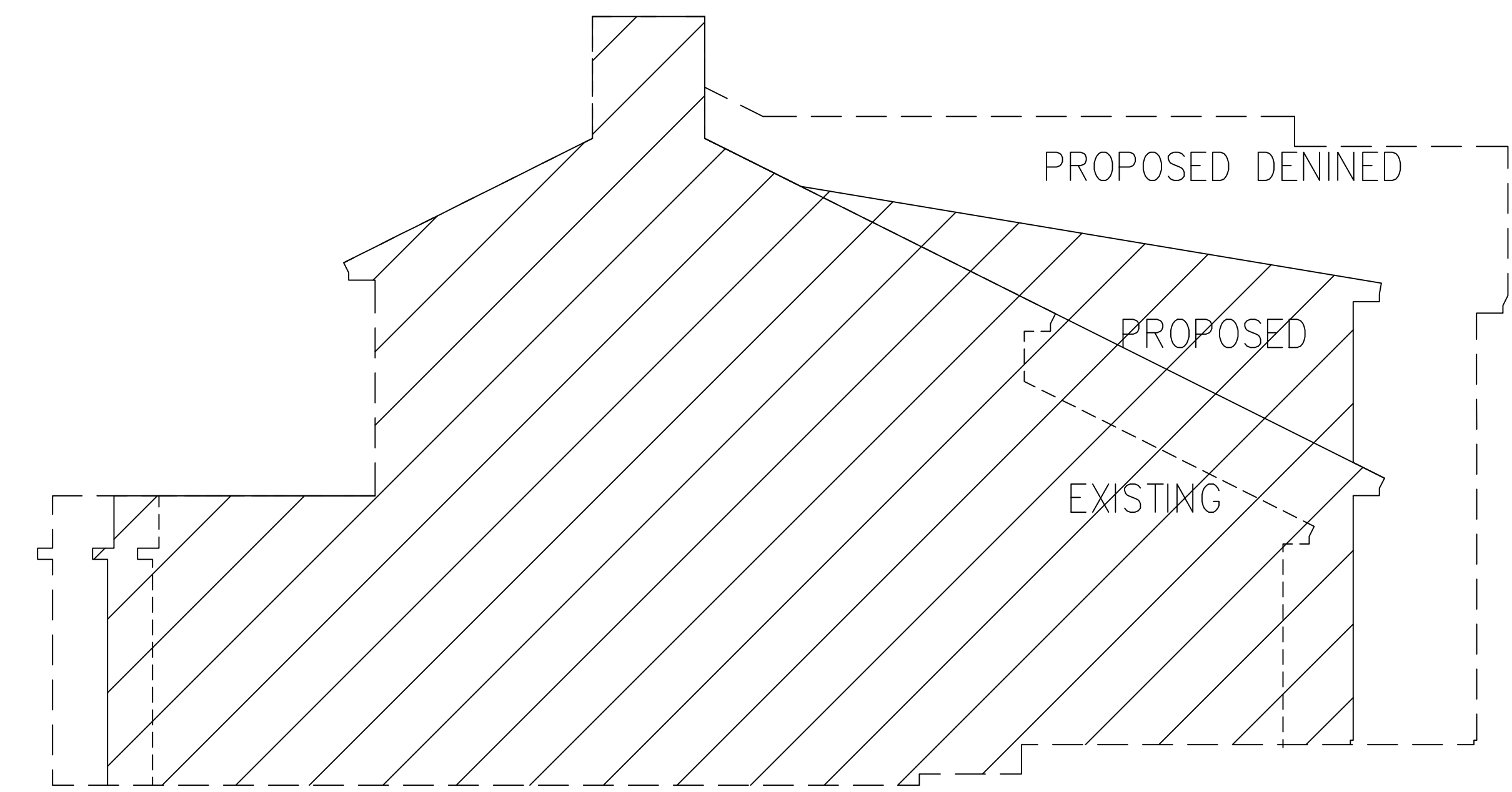

PROPOSED DENIED



LEFORT ASSOCIATES
24 WARD LANE
STAMFORD, CT 06907
www.lefortassociates.com

ADDITION &
RENOVATIONS:

FRANK ZMUDA

41 WRIGHT ROAD
WESTPORT, CT 06460

SCALE:
3/16"=1'-0"

DRAWN BY:
LEL

DATE:
2022 DECEMBER 1

PROJECT NO.
2216

PHASE PR
PR-6

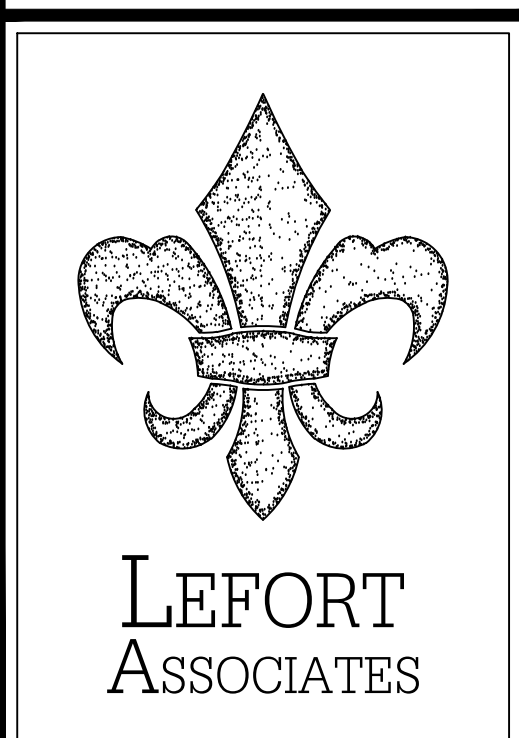



HISTORIC RESOURCES INVENTORY - BUILDING AND STRUCTURES

Please send completed form to: Stacey Vairo, National Register and State Register Coordinator,
Connecticut Commission on Culture & Tourism, One Constitution Plaza, 2nd Floor, Hartford, CT 06103

* Note: Please attach any additional or expanded information on a separate sheet.

GENERAL INFORMATION

Building Name (Common) _____

Building Name (Historic) Zalman Sanford House No. 2

Street Address or Location 41 Wright Street

Town/City Westport Village _____ County Fairfield

Owner(s) Frank J. Clark Public Private

PROPERTY INFORMATION

Present Use: Residential

Historic Use: Residential

Accessibility to public: Exterior visible from public road? Yes No

Interior accessible? Yes No If yes, explain _____

Style of building Greek Revival Date of Construction ca. 1855

Material(s) (Indicate use or location when appropriate):

- | | | | | |
|---|---|--------------------------------------|---------------------------------------|--|
| <input checked="" type="checkbox"/> Clapboard | <input type="checkbox"/> Asbestos Siding | <input type="checkbox"/> Brick | <input type="checkbox"/> Wood Shingle | <input type="checkbox"/> Asphalt Siding |
| <input checked="" type="checkbox"/> Fieldstone | <input type="checkbox"/> Board & Batten | <input type="checkbox"/> Stucco | <input type="checkbox"/> Cobblestone | <input type="checkbox"/> Aluminum Siding |
| <input checked="" type="checkbox"/> Concrete (Type replacement _____) | <input type="checkbox"/> Cut Stone (Type _____) | <input type="checkbox"/> Other _____ | | |

Structural System

- Wood Frame Post & Beam Balloon Load bearing masonry Structural iron or steel
 Other _____

Roof (Type)

- Gable Flat Mansard Monitor Sawtooth
 Gambrel Shed Hip Round Other _____

(Material)

- Wood Shingle Roll Asphalt Tin Slate Asphalt Shingle
 Built up Tile Other _____

Number of Stories: 2 Approximate Dimensions _____

Structural Condition: Excellent Good Fair Deteriorated

Exterior Condition: Excellent Good Fair Deteriorated

Location Integrity: On original site Moved When? _____

Alterations? Yes No If yes, explain: Enclosed entrance, rear ell, attached garage

FOR OFFICE USE: Town # _____ Site # _____ UTM _____

District: S NR If NR, Specify: Actual Potential

PROPERTY INFORMATION (CONT'D)

Related outbuildings or landscape features:

- Barn Shed Garage Carriage House Shop Garden
 Other landscape features or buildings: _____

Surrounding Environment:

- Open land Woodland Residential Commercial Industrial Rural
 High building density Scattered buildings visible from site

• Interrelationship of building and surroundings:

See Continuation Sheet

• Other notable features of building or site (*Interior and/or Exterior*)

See Continuation Sheet

Architect _____ Builder _____

• Historical or Architectural importance:

See Continuation Sheet

• Sources:

See Continuation Sheet

Photographer PAL Inc. _____ Date 10/4/2011 _____

View _____ Negative on File _____

Name _____ Date 10/4/2011 _____

Organization PAL Inc. _____

Address 210 Lonsdale Avenue, Pawtucket, RI 02860 _____

• Subsequent field evaluations:

Threats to the building or site:

- None known Highways Vandalism Developers Renewal Private
 Deterioration Zoning Other _____ Explanation _____

STATE OF CONNECTICUT

COMMISSION ON CULTURE & TOURISM
STATE HISTORIC PRESERVATION OFFICE

One Constitution Plaza, Second Floor, Hartford, CT 06103

HISTORIC RESOURCE INVENTORY FORM

For Buildings and Structures

FOR OFFICE USE ONLY

TOWN NO.: SITE NO.:

UTM: 18/____/____/____/____/____

QUAD:

DISTRICT:

NR: Actual

Potential

CONTINUATION SHEET

Item Number: _____ Date: October 2011

PAL, Pawtucket, RI 02860

41 Wright Street, Westport, CT

Interrelationship of building and surroundings:

The house occupies a grass lawn that gently slopes towards Wright Street and faces north. The lot is bordered by tall trees and large shrubs that shield the front of the house. A gravel driveway runs along the west side of the house.

Other notable features of building or site (Interior and/or Exterior):

The building is a two-story, three-bay-by-one-bay, Greek Revival style residence. The asphalt shingle-clad, front-gable roof has wide rake boards and shallow gable returns with a brick chimney rising from the center of the ridge. The walls are clad in clapboard with narrow corner boards and rest on a concrete foundation. The main entrance is located in the east bay of the north (facade) elevation and consists of a wood panel door with four light sidelights within an enclosed, gable roof porch. The porch has a pediment with a wide entablature supported by narrow Doric columns and pilasters. The wood panel porch door has a twelve-light window in the top half flanked by four-light sidelights. Each side of the porch has large sixteen-light windows. A screen porch with squared Doric columns and a balustrade is located on the south end of the east elevation. Windows consist primarily of six-over-six, double-hung sash with wide lintels. A rectangular, fifteen-light, fixed sash is located under the gable on the facade. A large, two-story rear ell and attached garage project from the south (rear) elevation. The building plan is relatively intact, minor alterations include the replacement of some exterior materials.

Historical or Architectural importance:

The house was most-likely built by Zalman Sanford ca. 1855, who also constructed the house at 35 Wright Street at that time. Sanford also appears as the owner of the property on the 1855 map of Westport. He sold the property to Capt. Peter Buckley in 1857. It later appears on the 1876 map of Westport, where it is listed as the house of Capt. P. Buckley. The property remains in the Buckley family until 1927 when it was purchased by writer John M. Clark and his wife, Winifred. The Clarks owned the property through the twentieth century, with the listing switching from John M. Clark to Winifred M. Clark in the mid-1960s. The Clarks also remodeled the cow shed on the property into an in-law apartment. By 1985, the property was listed under Frank J., Frederick H.F., and Patricia A. Clark (relationship unknown). The current owner of the property is Frank J. Clark (relationship unknown).

Sources:

Beers, J.H. & Co. Atlas of the County of Fairfield. 1867; Cunningham, Jan. Kings Highway North HD NR. Hartford: Connecticut Historical Commission, 1997; Hopkins, G.M. Atlas of the County of Fairfield. 1879; Sanborn Fire Insurance Maps. 1891-1940; Westport Directory (W.D.). Loveland, CO: US West Marketing Resources, 1991; W.D. Chicago, IL: Johnson Publishing Co., 1985; W.D. Providence, RI: C. DeWitt White Co., 1917-1918; W.D. New Haven: The Price & Lee Co., 1923-1974. WHD files.

STATE OF CONNECTICUT

**COMMISSION ON CULTURE & TOURISM
STATE HISTORIC PRESERVATION OFFICE**
One Constitution Plaza, Second Floor, Hartford, CT 06103

HISTORIC RESOURCE INVENTORY FORM
For Buildings and Structures

CONTINUATION SHEET

Item Number: _____ Date: October 2011
PAL, Pawtucket, RI 02860

41 Wright Street, Westport, CT

PHOTOGRAPHS

<i>FOR OFFICE USE ONLY</i>	
TOWN NO.:	SITE NO.:
UTM: 18/____/____/____/____/____	
QUAD:	
DISTRICT:	NR: Actual Potential



View of the north elevation.



Detail of the main entrance.

STATE OF CONNECTICUT

CONNECTICUT HISTORICAL COMMISSION
59 South Prospect Street, Hartford, CT 06106

HISTORIC RESOURCES INVENTORY FORM
For Buildings and Structures

CONTINUATION SHEET

Item number: _____

PAL, Pawtucket, RI 02860
June 2000

Address: 41 Wright Street

Name: Zalmon Sanford/ Capt. Peter
Bulkley House

NR District: Kings Highway North Historic
District

Local District: Kings Highway North Historic
District

Neg No.: 8:25

HRS ID No.: 0975





Lifestyle Series Double-Hung

Unit Sections

wood window

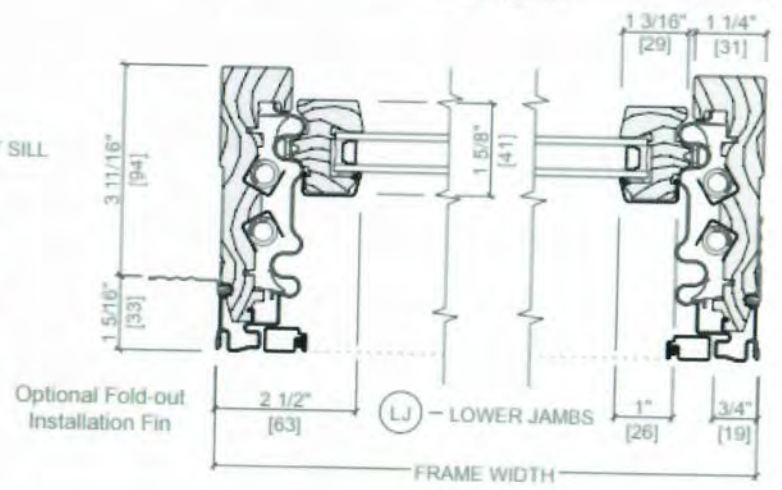
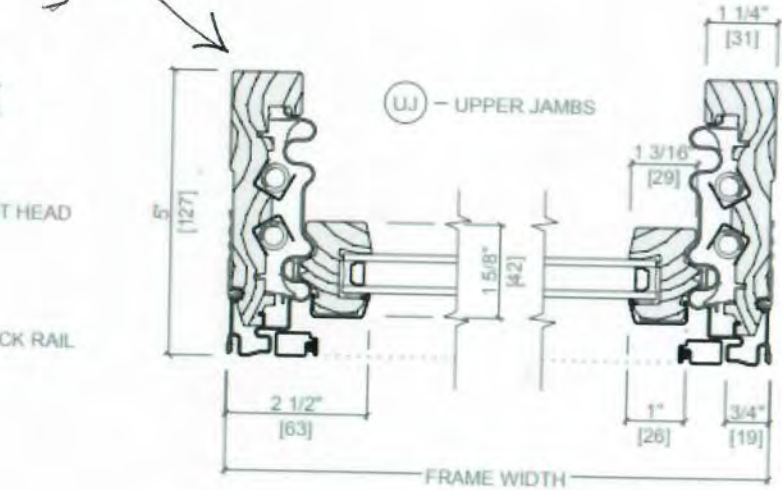
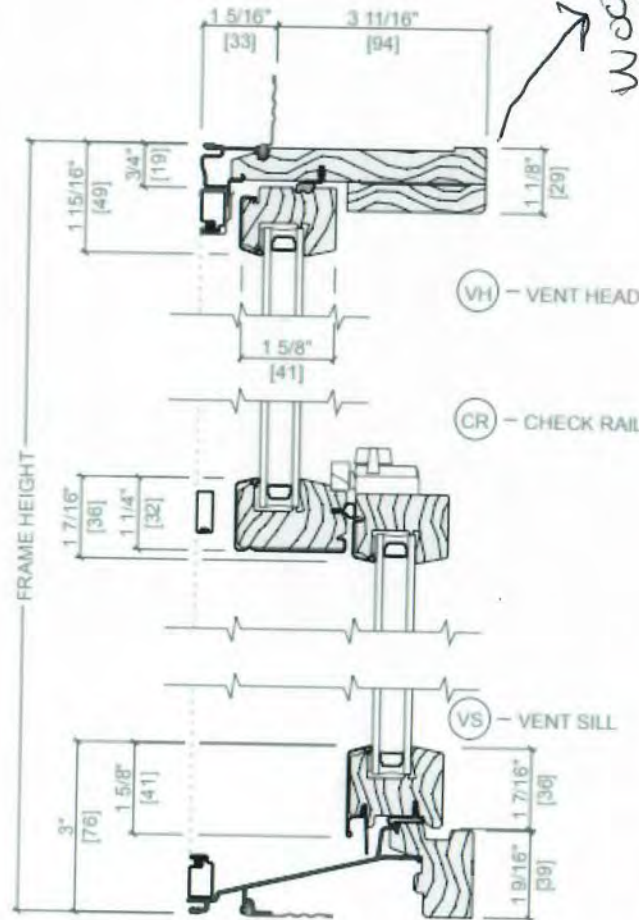
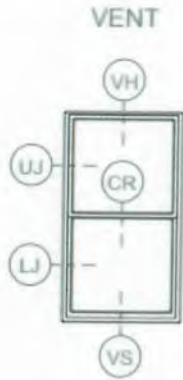

Grille Profiles

Simulated-Divided-Light Grilles

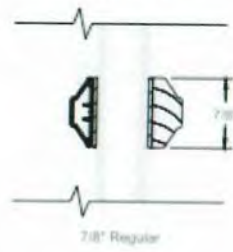

Simulated-Divided-Light Grilles with optional spacer

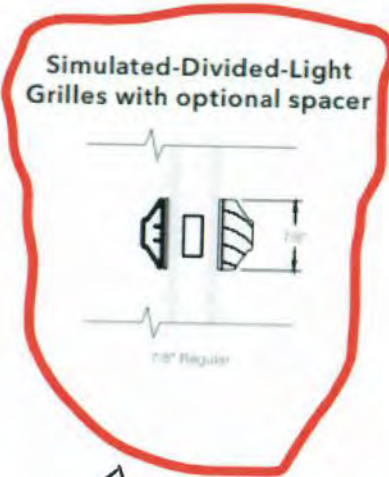

Grilles-Between-the-Glass



Grille Patterns

Applied fixed grilles w/ spacer bar. Identical to original

Grilles-Between-the-Glass and Simulated-Divided-Light Grilles



9-Lite Prairie



9-Lite Prairie Top Sash Only



Top Row



Cross

9-Lite Prairie

- Standard corner lite dimension for Prairie patterns = 2-1/2" VG.
- Available in transoms ≥ 1'3" height and width.

Cross

- Minimum DH frame height 35".
- Horizontal bar will be at 1/2" of the VG height of the top sash.

Top Row

- Minimum DH frame height 35".
- Horizontal bar will be at 1/2" of the VG height of the top sash.

For traditional patterns, see size tables.

will match 6 over 6 of original

DETAIL AND SILL/DRIP PROFILES

AZEK® Drip profiles can be used as a water table or brick ledge for separation and watershed against two different materials. AZEK's Sill profiles shed water and offer architectural detail.



Denotes Water Management Drip Edge

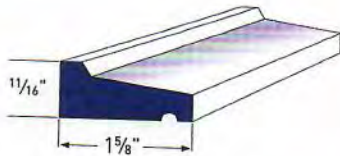

DRIP CAP AZM-197
LENGTH: 16'

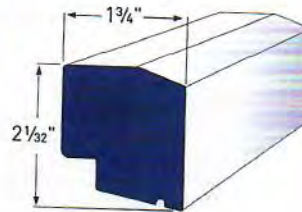

~~HISTORIC SILL AZM-6930~~
LENGTH: 16'

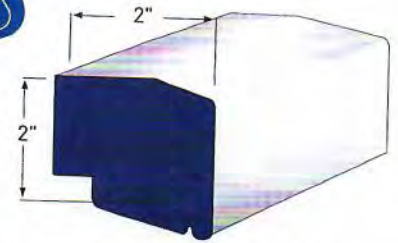

LARGE SILL NOSE AZM-7979
LENGTH: 16'

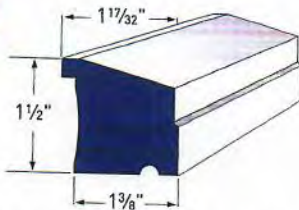

SUB SILL NOSE AZM-6933
LENGTH: 16'

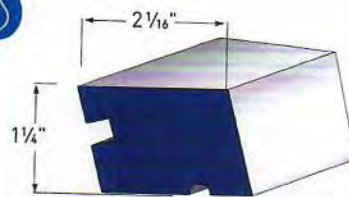

WINDOW SILL NOSE AZM-7974
LENGTH: 12'

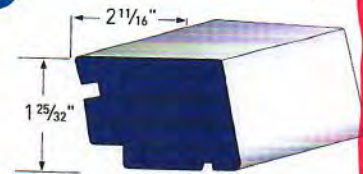

~~LARGE HISTORIC SILL AZM-7958~~
LENGTH: 16'

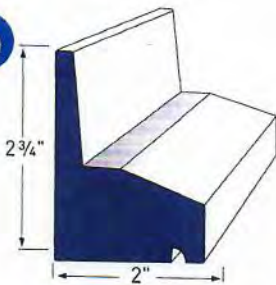

WATER TABLE AZM-6935
LENGTH: 18'

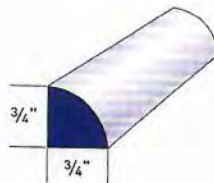

QUARTER ROUND AZM-105
LENGTH: 16'

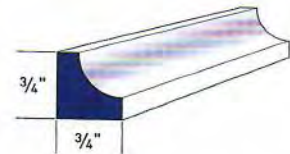

SCOTIA AZM-93
LENGTH: 16'

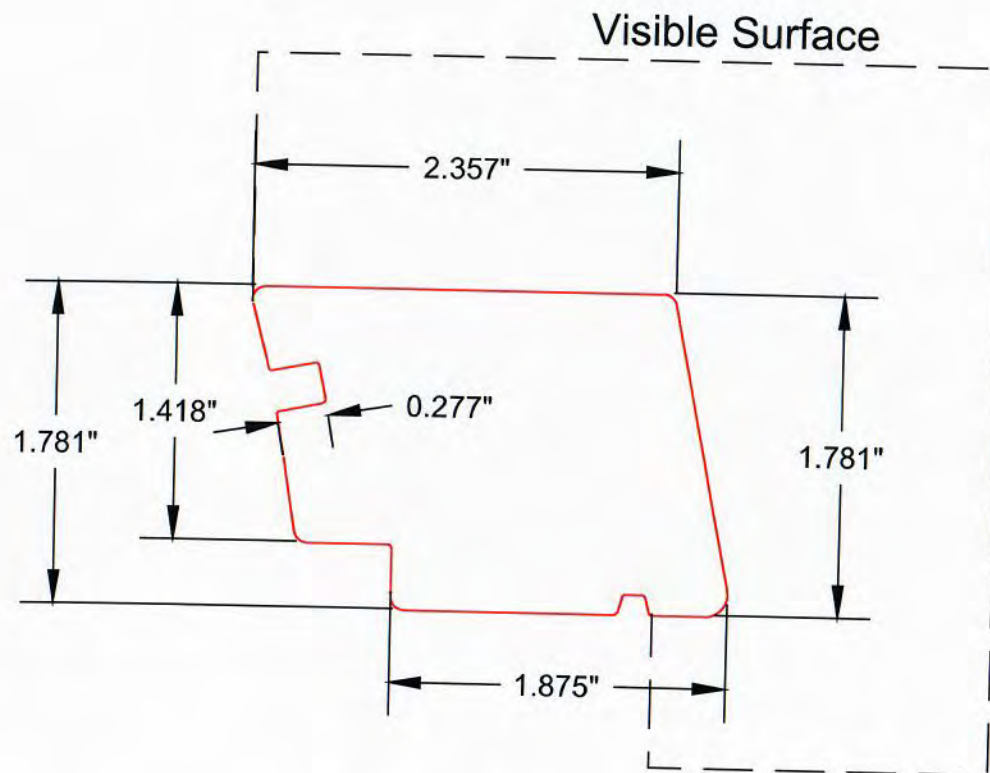

AZEK BUILDING PRODUCTS
 WWW.AZEK.COM
 (877) ASK-AZEK



LG Historic Sill 16' 7958

AMHS03T92CB

1-25/32" x 2-11/16"



CLASSIC AZEK

Available in smooth and woodgrain finish



PAINTPRO® TECHNOLOGY

Reversible (one side smooth, one side woodgrain)



Smooth
Finish



Woodgrain
Finish

All AZEK Trim is long-lasting, moisture-resistant, and keeps its appearance with very little maintenance. Easily mill and route our trim, or heat form it before painting, for exquisite customized or curved applications. Classic AZEK Trim's brilliant white complements any exterior while AZEK Trim with PaintPro® was made to be painted.

PROTECTIVE FILM TO KEEP CLASSIC WHITE TRIM CLEAN

Classic AZEK Trim with protective film is available for smooth and woodgrain finishes. To ensure it looks as beautiful on your clients' home as it does when it leaves our facilities, AZEK Trim comes with a protective film to preserve the crisp white semi-matte finish.

NOMINAL THICKNESS	NOMINAL WIDTH						
	4	5	6	8	10	12	16
5/4	SW	SW	SW	SW	SW	SW	SW
4/4	SW	SW	SW	SW	SW	SW	SW
5/8	SW	SW	SW	SW	SW	SW	SW



The film protects AZEK Trim through every production phase:

- Shipping
- Repackaging
- Installation
- Storage
- Handling

AZEK Trim with protective film should be kept dry prior to installation. Do not expose film to direct sunlight for extended periods. Protective film can be removed prior to, during, or immediately after installation.

AZEK® TRIM

8/4 X THICKNESS

NOMINAL	ACTUAL	18'
8/4 x 4	1 1/2" x 3 1/2"	S
8/4 x 6	1 1/2" x 5 1/2"	S
8/4 x 8	1 1/2" x 7 1/4"	S
8/4 x 10	1 1/2" x 9 1/4"	S
8/4 x 12	1 1/2" x 11 1/4"	S

6/4 X THICKNESS

NOMINAL	ACTUAL	20'
6/4 x 4	1 1/4" x 3 1/2"	W
6/4 x 6	1 1/4" x 5 1/2"	W
6/4 x 8	1 1/4" x 7 1/4"	W
6/4 x 10	1 1/4" x 9 1/4"	W
6/4 x 12	1 1/4" x 11 1/4"	W

5/4 X THICKNESS

NOMINAL	ACTUAL	12'	16'	18'	20'
5/4 x 4	1" x 3 1/2"	SW	P	SW	SW
5/4 x 5	1" x 4 1/2"	SW		SW	SW
5/4 x 6	1" x 5 1/2"	SW	P	SW	SW
5/4 x 8	1" x 7 1/4"	SW	P	SW	SW
5/4 x 10	1" x 9 1/4"	SW	P	SW	SW
5/4 x 12	1" x 11 1/4"	SW	P	SW	SW
5/4 x 16	1" x 15 1/4"	SW	P	SW	SW

4/4 X THICKNESS

NOMINAL	ACTUAL	12'	16'	18'
1 x 2	3/4" x 1 1/2"		P	SW
1 x 3	3/4" x 2 1/2"		P	
1 x 4	3/4" x 3 1/2"	SW	P	SW
1 x 5	3/4" x 4 1/2"	SW		SW
1 x 6	3/4" x 5 1/2"	SW	P	SW
1 x 8	3/4" x 7 1/4"	SW	P	SW
1 x 10	3/4" x 9 1/4"	SW	P	SW
1 x 12	3/4" x 11 1/4"	SW	P	SW
1 x 16	3/4" x 15 1/4"	SW	P	SW

5/8 X THICKNESS

ACTUAL	12'	18'
5/8" x 3 1/2"	SW	SW
5/8" x 5 1/2"	SW	SW
5/8" x 7 1/4"	SW	SW
5/8" x 9 1/4"	SW	SW
5/8" x 11 1/4"	SW	SW
5/8" x 15 1/4"	SW	SW

Smooth
Finish (S)



Woodgrain
Finish (W)



PaintPro
Technology (P)



PaintPro Sheet Sheet

ATM Sheet

AZEK® SHEET

Applications over 16" wide are easy with AZEK Sheet.

Use Sheet for bay windows, dormers, and raised panels.

SHEET

ACTUAL	8'	10'	12'	18'	20'
3/8" x 4"*	SW	SW	S	S	
1/2" x 4"*	SWP	SWP	SP	S	
5/8" x 4'	S	S	S	S	
3/4" x 4'	SWP	SWP	S	S	
1" x 4'	S	S	S	S	S

AZEK TO MILL (ATM)

ATM's thick profile makes it an ideal material for fabrication. Its consistent density offers a superior product for milling operations.

AZEK TO MILL

ACTUAL	8'	10'	12'	18'	20'
1 1/4" x 9 1/4"				S	
1 1/2" x 3 1/2"				S	
1 1/2" x 5 1/2"				S	
1 1/2" x 7 1/4"				S	
1 1/2" x 9 1/4"				S	
1 1/2" x 11 1/4"				S	
1 1/4" x 48" Sheet	S				
1 1/2" x 48" Sheet	S	S	S		S

S1S2E TRIM BOARDS

ALL S1S2E BOARDS ARE PROTECTED

16' 20' **30** Year warranty* on Protected boards

- • 1x2
- • 1x3
- • 1x4
- • 1x6
- • 1x8
- • 1x10
- • 1x12
- • 5/4 x3
- • 5/4 x4
- • 5/4 x6
- • 5/4 x8
- • 5/4 x10
- • 5/4 x12
- • 2 x2
- • 2 x4
- • 2 x6
- • 2 x8
- • 2 x10
- • 2 x12



REVERSIBLE ROUGH SAWN ON ONE SIDE, SMOOTH ON OTHERS WITH EASED EDGES

All S1S2E products are protected with a 30 year warranty against rot, insects and mold. Durable for the exterior, healthy for the interior.

1/1

S1S2E BOARDS: REVERSIBLE ROUGH-SAWN, 2 EASED EDGES

SCALE

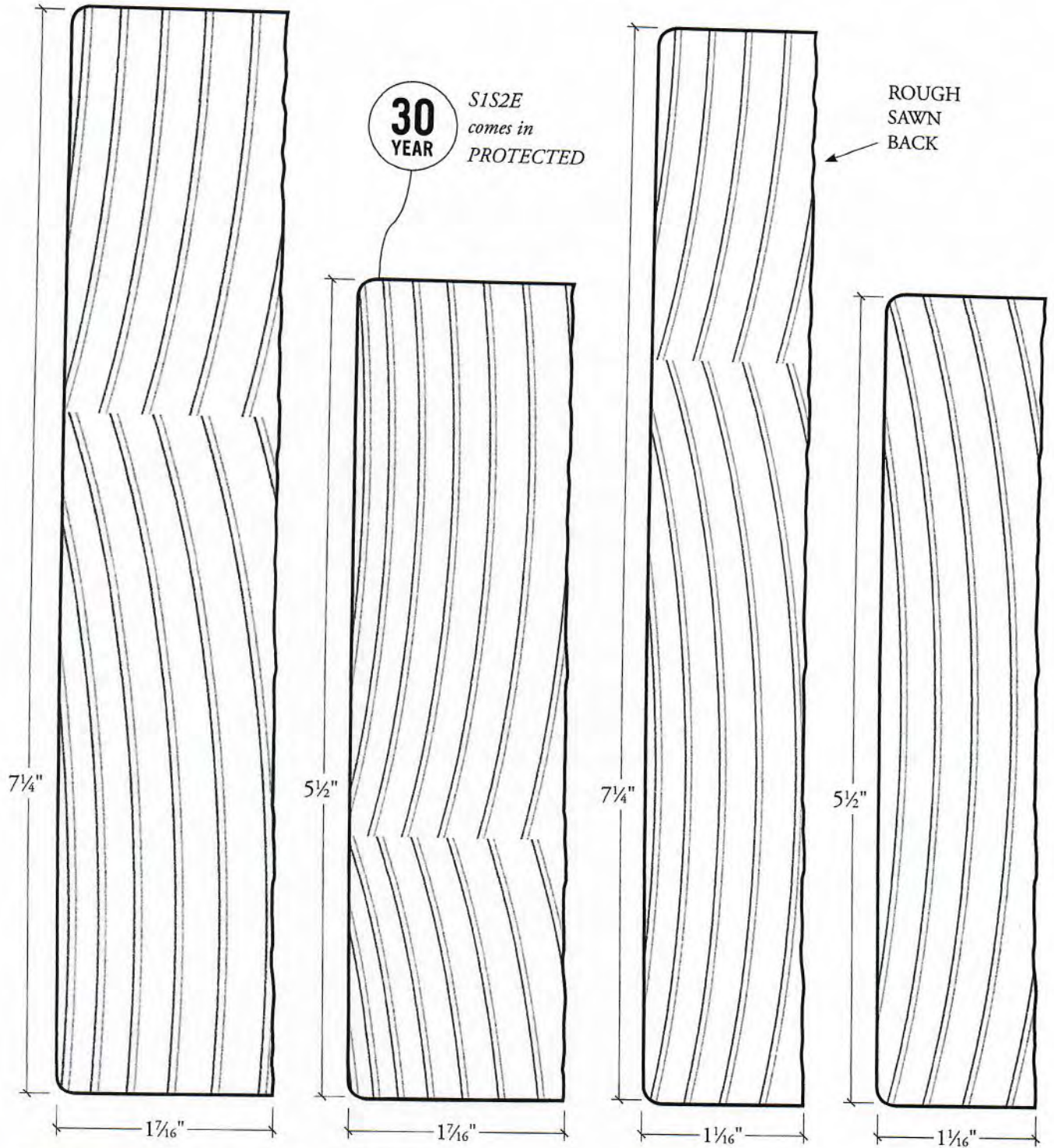

SELECTED FULL SCALE SAMPLES

S1S2E BOARDS (WITH WindsorONE PROTECTED 30yr WARRANTY)

S1S2E

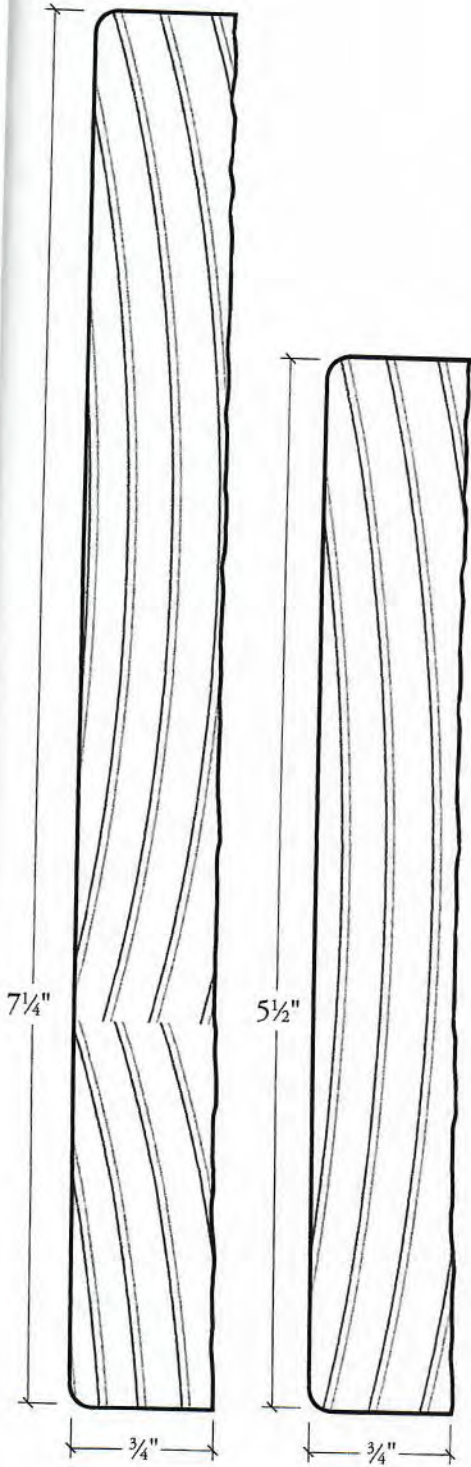

lengths 16' 20'	nominal sizes	net sizes	1/4 scale of profiles *(also shown in full scale on left)
• •	1 x 2	3/4" x 1 1/2"	
• •	1 x 3	3/4" x 2 1/2"	
• •	1 x 4	3/4" x 3 1/2"	
• •	1 x 6	3/4" x 5 1/2"	
• •	1 x 8	3/4" x 7 1/4"	
• •	1 x 10	3/4" x 9 1/4"	
• •	1 x 12	3/4" x 11 1/4"	
• •	5/4 x 3	1 1/16" x 2 1/2"	
• •	5/4 x 4	1 1/16" x 3 1/2"	
• •	5/4 x 6	1 1/16" x 5 1/2"	
• •	5/4 x 8	1 1/16" x 7 1/4"	
• •	5/4 x 10	1 1/16" x 9 1/4"	
• •	5/4 x 12	1 1/16" x 11 1/4"	
• •	2 x 2	1 1/16" x 1 1/2"	
• •	2 x 4	1 1/16" x 3 1/2"	
• •	2 x 6	1 1/16" x 5 1/2"	
• •	2 x 8	1 1/16" x 7 1/4"	
• •	2 x 10	1 1/16" x 9 1/4"	
• •	2 x 12	1 1/16" x 11 1/4"	

S1S2E 1/4 SCALE

3/4
SCALE

EXTERIOR MOLDINGS PROTECTED *with a 30YR WARRANTY**

EXTERIOR MOLDINGS

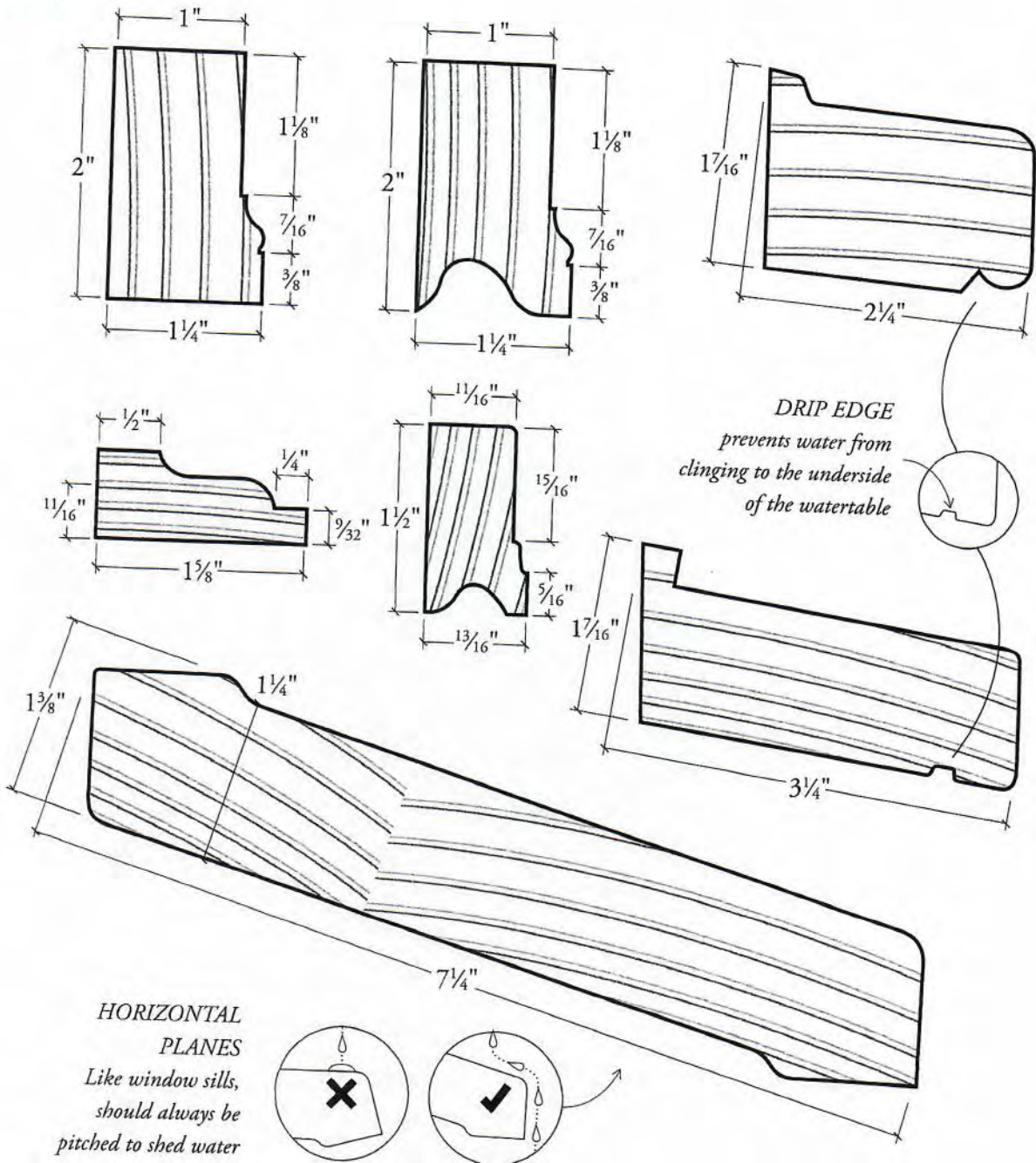

EXTERIOR MOLDINGS

- W1-381 Brick Mold
- W1-381K Brick w/ Key
- W1-630 Watertable
- W1-516 Shingle Mold
- W1-618 Stucco Mold
- W1-634 Watertable
- W1-640 Reversible Sill

*Warranty based on proper installation, see WindsorONE.com/install for details 57

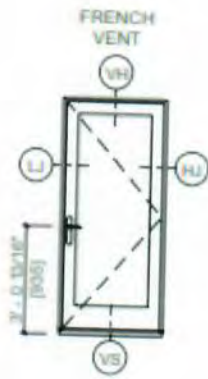

Head Height Dimension shown in this section of unit based on door handle installation method used and finished bearing conditions will cause handle height to vary. Show not using the standard Pella multi-point lock and hardware specified in 'No Lockless Door' see our website for details.

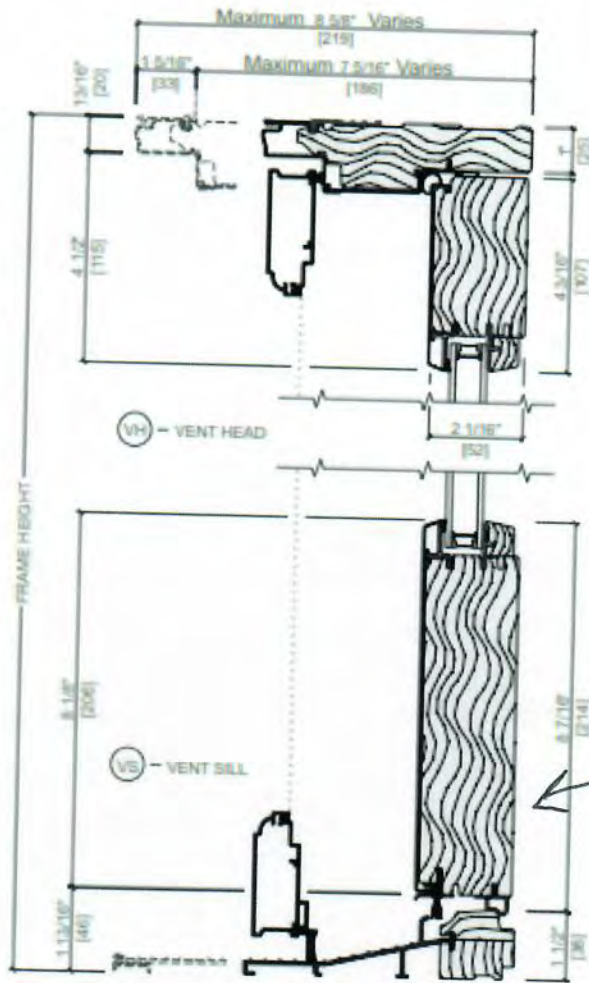

wood constructed door

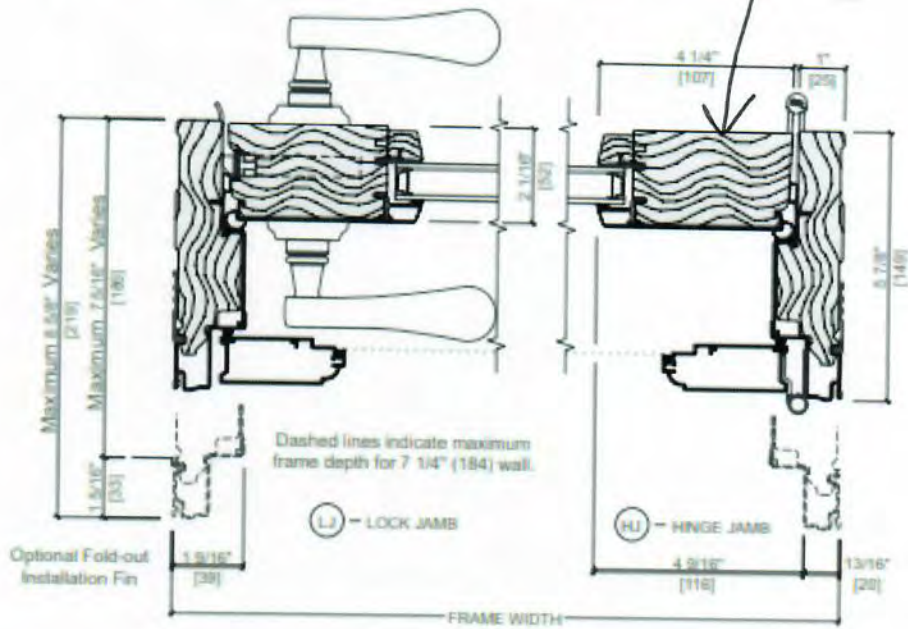

Dashed lines indicate maximum frame depth for 7 1/4\"/>

Scale 3\"/>



Lifestyle Series In-Swing Patio Door

Grilles

Grille Profiles - Dual-Pane

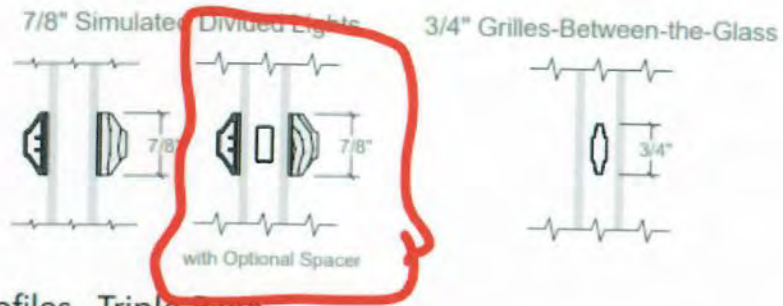

Grille Profiles - Triple-Pane

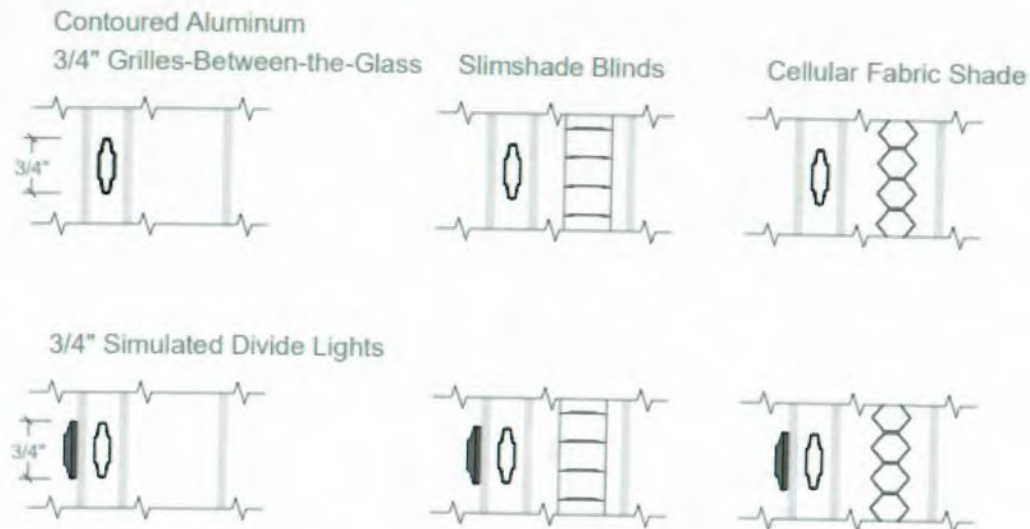

Contact your local Pella sales representative for current availability.

Grille Patterns

Landmark® TL Solaris Shingles

PRODUCT INFORMATION:

The Landmark® TL Solaris innovative technology produces a shingle that reflects solar energy in a traditional color palette. All colors are rated by Cool Roof Rating Council (CRRC) and can be used to comply with California Title 24 Part 6 Cool Roof Requirements and LA County Title 31 Steep Slope Residential cool roof provisions. These shingles are constructed using three laminated layers of the industry's most durable materials, providing a dramatically thick roofing product styled with the classic appeal of wood shakes. The overall dimensions of this shingle are 13 1/4" x 40". It is designed to resist blow off in high wind conditions up to 110-mph with normal installation and 130-mph with special installation.



Colors: Please refer to product brochure or CertainTeed website for the colors available in your region.

Color	CRRC Product ID#	Solar Radiative Properties					
		Solar Reflectance		Thermal Emittance		Solar Reflective Index	
		Initial	Aged	Initial	Aged	Initial	Aged
Country Gray	0668-0149	0.21	0.22	0.92	0.93	21	23
Moire Black	0668-0148	0.19	0.20	0.93	0.93	19	20
Platinum	0668-0147	0.21	0.21	0.93	0.93	22	22

Limitations: It is recommended to apply these shingles at slopes of 4" per foot and greater in order to achieve optimum appearance. Low slope applications (2:12 to < 4:12) require CertainTeed's WinterGuard® Waterproofing Shingle Underlayment, or its equivalent meeting ASTM D1970, to be applied to the entire deck surface, according to application instructions provided with the product and on the shingle package. In areas where icing along the eaves can cause the back-up of water (all slopes); apply WinterGuard, or its equivalent, according to application instructions provided with the product and on the shingle package.

Product Composition: Landmark TL Solaris shingles are composed of a fiber glass mat base. Ceramic-coated mineral granules with high solar reflectance are tightly embedded in carefully refined, water-resistant asphalt. Three pieces of the shingle are firmly laminated together in a special, tough asphaltic cement. All Landmark TL Solaris shingles have self-sealing adhesive strips.

Applicable Standards:

ASTM D3018 Type 1
ASTM D3462
ASTM E108 Class A Fire Resistance
ASTM D3161 Class F Wind Resistance
ASTM D7158 Class H Wind Resistance

ICC-ES ESR-1389
UL 790 Class A Fire Resistance
Florida Product Approval # FL5444
Meets TDI Windstorm Requirements

Technical Data:

Weight/Square (approx.): 305 lb.
Dimensions (overall): 13 1/4"x 40"
Shingles/Square: 64
Weather Exposure: 5-5/8"

INSTALLATION

Detailed installation instructions are supplied on each bundle of Landmark TL Solaris shingles and must be followed. Separate application sheets may also be obtained from CertainTeed.

Hips and Ridges: For a complementary color, use CertainTeed's enhanced high profile accessory shingle, Mountain Ridge®, of a like color name for capping with hips and ridges.

MAINTENANCE

Landmark TL Solaris shingles do not require maintenance when installed according to manufacturer's application instructions. However, to protect the investment, any roof should be routinely inspected at least once a year. Older roofs should be looked at more frequently.

WARRANTY

Landmark TL Solaris shingles carry a lifetime limited, transferable warranty against manufacturing defects. In addition, all Landmark TL Solaris shingles carry 10-year SureStart™ Protection. For specific warranty details and limitations, refer to the warranty itself (available from the local supplier, roofing contractor or on-line at www.certainteed.com).

TECHNICAL SUPPORT

Technical Service Department: 800-345-1145
e-mail: RPG.T.Services@saint-gobain.com

FOR MORE INFORMATION

Customer Experience Team: 800-233-8990
e-mail: gethelp@saint-gobain.com
Web site: www.certainteed.com



