

# DESIGN STANDARDS FOR OFF-STREET PARKING AND LOADING

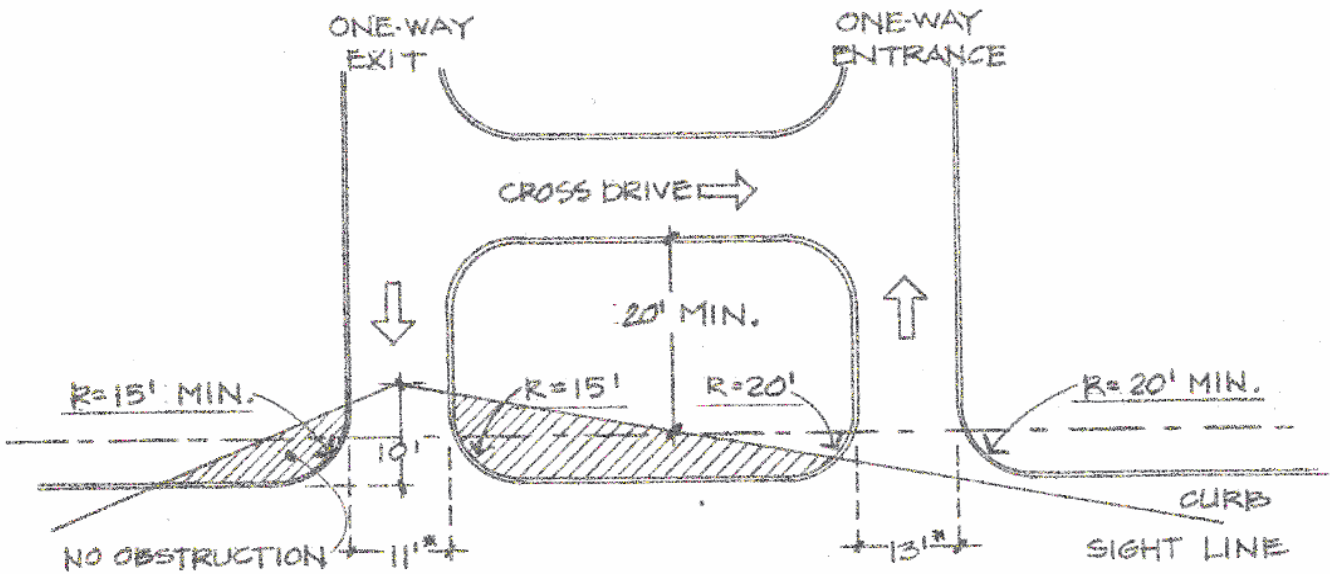
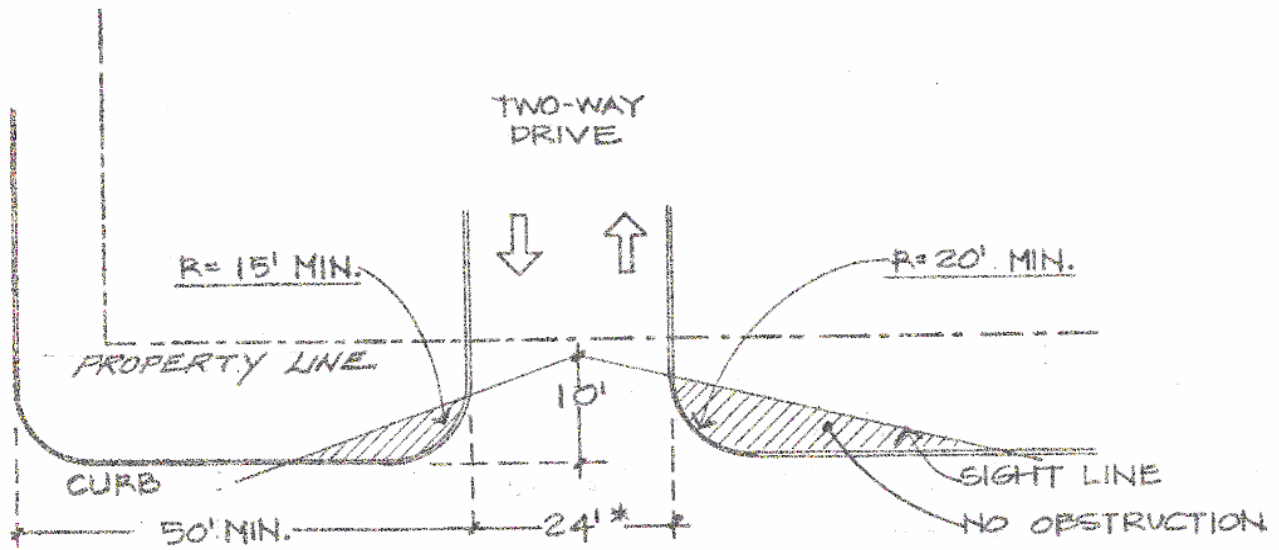

\* MINIMUM OF 18 FT. 2-WAY DRIVE, 11 FT. 1-WAY ENTRANCE AND/OR 9 FT. 1-WAY EXIT MAY BE PERMITTED PROVIDED THE GFA OF ALL BUILDINGS ON THE LOT IS LESS THAN 5000 SQ. FT. AND NO ANGLE PARKING IS PROVIDED ALONG THE DRIVEWAY.